



**THE POWER OF EDM  
IN FULL FORCE**

**TITAN**  
INTERNATIONAL SALES



Contact: Ken Otzel / (508)958-5565  
High Performance Machinery  
[otzl@aol.com](mailto:otzl@aol.com) - or - [otzelk8@gmail.com](mailto:otzelk8@gmail.com)

**TITAN**  
INTERNATIONAL SALES



## **BUY LOCAL WITH GLOBAL SUPPORT**

Our machines, made in the USA, allow us to deliver high-quality, cutting-edge EDM drills, with qualified on-site service, immediate OEM replacement parts, turnkey application support, and thorough training.

### **Built out of necessity. Delivered with pride.**

Titan International Sales was founded with the idea of offering a quality EDM hole driller with the flexibility to adapt to a wide variety of applications. Since then, our company has grown into one of the premier distributors of EDM drilling equipment in the United States.

### **Locally designed. Locally produced. Committed to United States manufacturing.**

Our machines are designed, sourced and produced in the United States. We use locally sourced components and fabricated products with vendors who are quality driven and committed to keeping jobs local. We have partnered with electrical, mechanical and software engineers who offer local around the clock support and have a proven track record.

Our in-house innovative design approach – combined with our willingness to deliver solutions adapted to customer applications – provide our customers with a significant productivity advantage over their competitors.



# FORCE

EDM Drilling Machines

## NEW REQUIREMENTS. NEW DEMANDS

Manufacturers are demanding tighter tolerances and work that requires more exotic materials. The Titan Force line of EDM Drills offers one of the most proficient cutting technology databases, covering materials ranging from tool steel to exotic alloys such as titanium and Inconel, while giving the user the flexibility to work with an electrode range from .001" to .250".

### Adaptive power supply. Maximum flexibility.

Sophisticated CNC architecture features depth controlled holes to .004", canned drilling cycles, polarity switching for electrode dressing and breakthrough detection for tight back-strike tolerances and improved cycle times for casting variations. Key features include:

- 70 peak amp power supply
- .001" to .250" electrode capabilities
- Fine amperage control selection in 0.1a increments
- On/off duty cycle range of 1 to 300us
- Capacitance selection from 0.1uf to 1.00uf
- Programmable electrode flushing pressure
- Adaptive servo feed rate control
- Polarity switching for electrode dressing

### Off the shelf components with brands that have a proven track record.

We build our machines with identifiable products that have demonstrated 100% uptime. This allows the end user to feel confident that this machine is the right solution for their application.



*"The ideal solution for bridging the gap between increased customer requirements and the lower production costs you need in order to compete, and the advanced capabilities you need to win."*

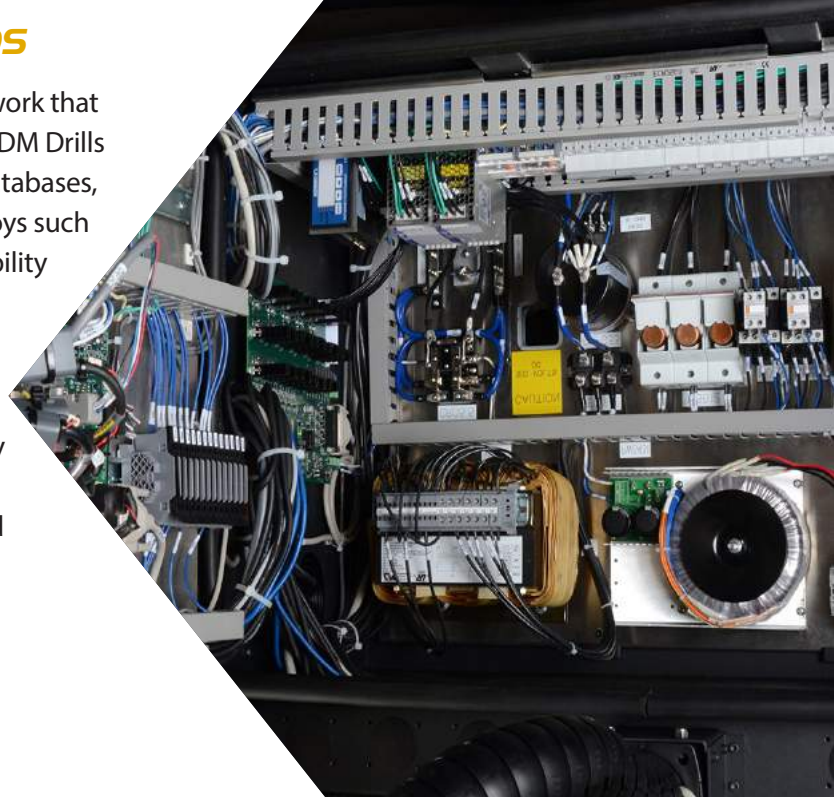

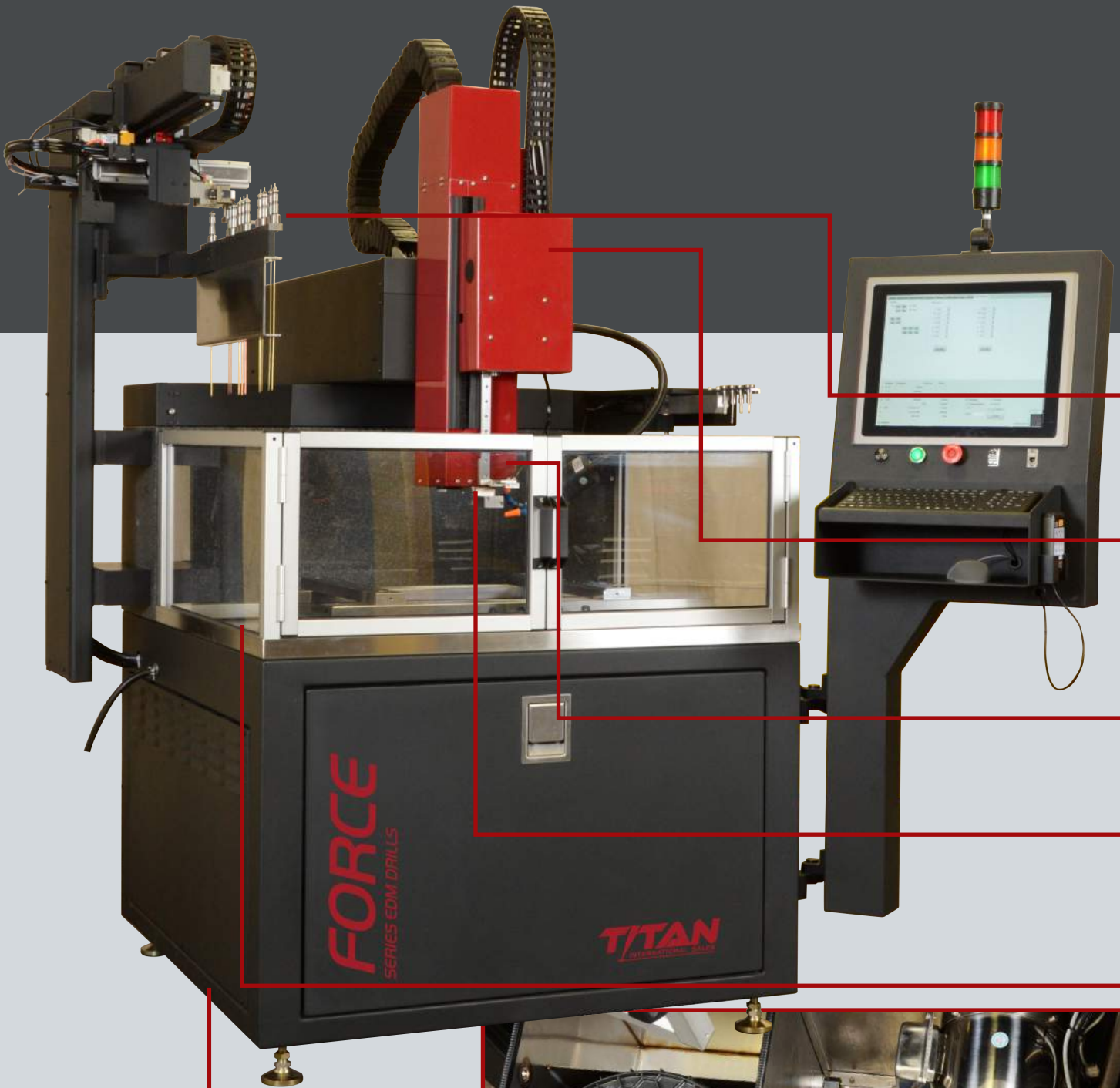

- Dual-side cabinet design, NEMA 4 enclosure completely isolates internal plumbing from electrical components for safety.
- Machines come pre-built for UL, CSA and CE third party inspections.

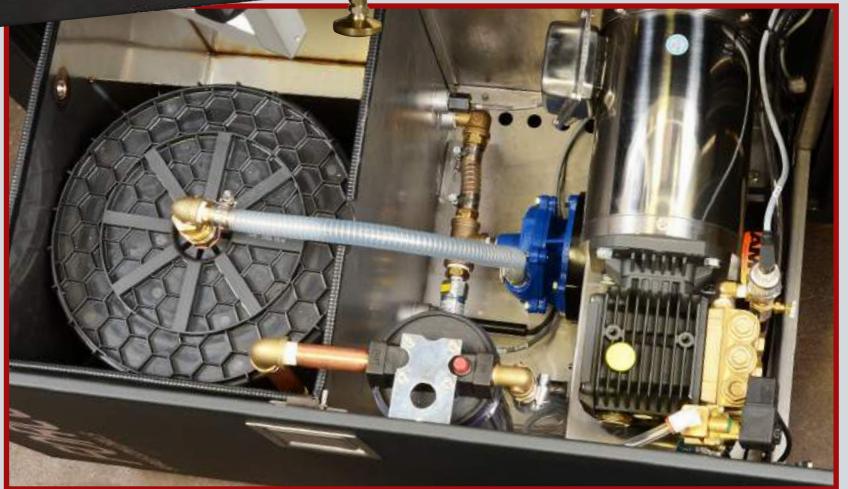

- Closed loop water filtration and deionizing system minimizes shop floor footprint. Optical level sensors and shut offs allow for easy maintenance monitoring.

## Every Component Engineered for Excellence

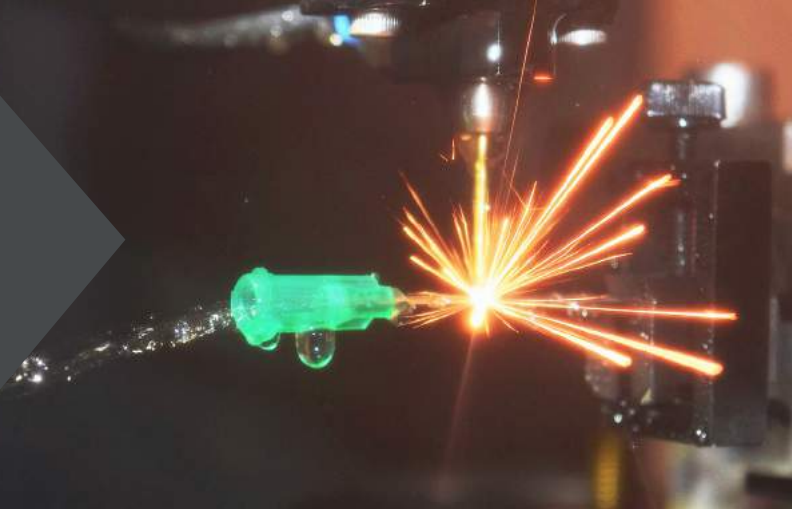

- Precision ground ball screws and linear motion guides extend machine life while offering increased stability, load capacity and controlled accuracy at multiple speeds.
- AC servo motors with absolute encoders for closed loop motion control feedback with no position loss from power brownouts, blackouts or temporary interruptions. Optional linear glass scales offer closed loop feedback independent of ball screw wear.
- Optional precision A axis tilting head  $\pm 45^\circ$  using harmonic drive technology for precision accuracy
- Industrial motion controller offers open architecture platform for standard G&M code programming with the flexibility for user or project specific customization.
- Granite machine tool base and work surface is an excellent electrical isolator that offers high precision, thermal stability, high stiffness, long-term stress-free use, and excellent damping characteristics.



- Stainless steel precision ground tooling system eliminates the need for additional tooling needs, while standard 25mm hole spacing allows for compatibility user's existing tooling brands.

## Advanced Software Features for More Control



- **Embedded Windows 7 OS** allows for controller flexibility and HMI customization.
- **Standard G code programming** G and M code programming; NC and DXF file reading function.
- **Breakthrough detection** offers machining stability during breakthrough; automatically adjusting for casting variations and improving cycle time on hole exit.
  - **Automatic electrode compensation** offers automatic reset and depth calculation of Z axis.
  - **Soft start feature reduces burr formation** by changing amperage levels during the burn process.
- **Cutting technology storage** allows for user defined setting management and sample test bank.
- **Programmable work piece pickup** ID, OD, cylindrical and shapes.
- **Depth control / blind hole capabilities** offer automatic probing of hole depth.

- **Multiple work piece setup** allows for simultaneous programming and machining.
- **On screen editing** offers point and click programming options with hole elimination.
- **Programmable "W" axis** for variable work piece height capability.
- **Canned drilling cycles** for flexible operation.
- **User level controls** with password protection and remote monitoring.
- **M Codes I/O functionality** for indexers, robotics, air chucks or other functions.



F O I



## **Maximum Uptime Starts with Maximum Support**

### **Training / Service / Application Support**

Our extensive service network boasts onsite and remote qualified support for any issues that may arise. Our sophisticated scheduling system allows us to offer one of the fastest service call turn-around times in the industry, utilizing regional service technicians to support our global presence.

Our users benefit from our remote diagnostic service, allowing us to collect important information from the machine and operator before a service technician steps in to your facility. This reduces investigative time, helping to keep maintenance and service costs lower.

### **Spare Parts Training / Consumables**

We offer the benefit of locally sourced components, allowing us to stock over 99% of parts in-house. Our warehouse also offers a reliable source for wear items such as filters and resin. Never wait for replacement parts again with our On-Demand ordering service, with same day turnaround for reduced downtime and increased productivity.

Our consumable group also stocks a wide variety of EDM electrodes, guides, seals for any application. From .0001" to .250":

**Electrodes:** brass, copper, copper-tungsten

**Standard or custom guides:** ceramic, carbide, silicone-nitrate

**Seals:** water based, oil based, polypropylene, ethylene-propylene

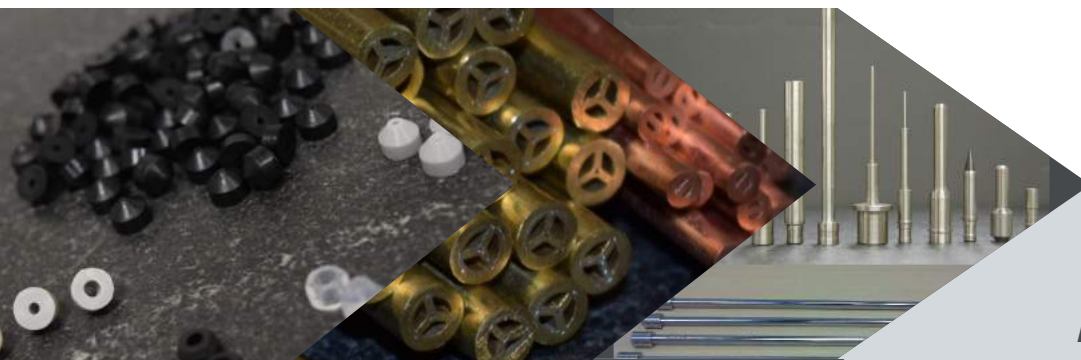

***When we say American Made, Global Support, it's not just a slogan. It's our commitment to you and your long-term success.***

# RCE

## MACHINE SPECIFICATIONS

### FORCE 30

### FORCE 60

### FORCE 90



Work table dimensions (X/Y)	45.0" x 35.0" / 1150mm x 900mm	45.0" x 35.0" / 1150mm x 900mm	45.0" x 35.0" / 1150mm x 900mm
Travel (X)	16.0" / 400mm	24.0" / 600mm	Available in either size travel
Travel (Y)	12.0" / 300mm	16.0" / 400mm	Available in either size travel
Travel (Z)	16.0" / 400mm	16.0" / 400mm	16.0" / 400
Travel (W)	16.0" / 400mm	16.0" / 400mm	16.0" / 400
Travel Tilt (A)	N/A	N/A	+/-45°
Possible electrode diameter (Inches/mm)	.001" - .236" / 0.025mm - 6.00mm	.001" - .236" / 0.025mm - 6.00mm	.001" - .236" / 0.025mm - 6.00mm
Maximum electrode length	16.0" / 400mm	16.0" / 400mm	16.0" / 400mm
Maximum workpiece height	18.0" / 450mm	18.0" / 450mm	18.0" / 450mm
Maximum workpiece weight (kg)	1000lb / 450kg	1000lb / 450kg	1000lb / 450kg
Machine weight (kg)	4000lb / 1800kg	4000lb / 1800kg	4000lb / 1800kg
Overall Dimensions (W x D x H)	68.4 x 74.1 x 98.1 (Inches) 1730 x 1900 x 2500 (mm)	68.4 x 74.1 x 98.1 (Inches) 1730 x 1900 x 2500 (mm)	68.4 x 74.1 x 98.1 (Inches) 1730 x 1900 x 2500 (mm)

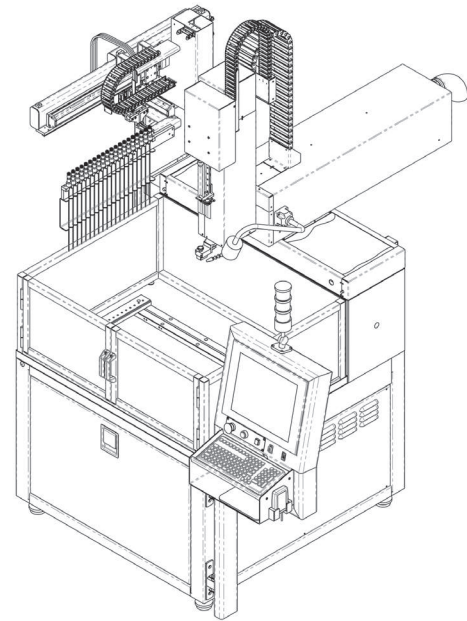
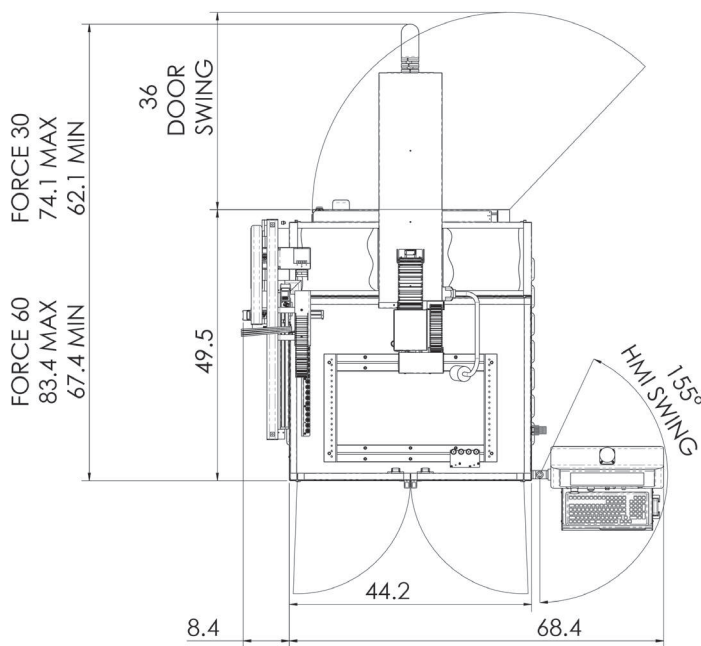

TITAN International Sales, Inc. | 72 Lancer Place Webster, NY 14580  
 Phone: 585-586-1020 | Fax: 585-586-1024  
[www.titanedm.com](http://www.titanedm.com)