

AgieCharmilles

FORM P 350

FORM P 600

FORM P 900



GF Machining Solutions: all about you

When all you need is everything, it's good to know that there is one company that you can count on to deliver complete solutions and services. From world-class electrical discharge machines (EDM), Laser texturing and Additive Manufacturing through to first-class Milling and Spindles, Tooling, Automation and software systems — all backed by unrivalled customer service and support — we, through our AgieCharmilles, Microlution, Mikron Mill, Liechti, Step-Tec and System 3R technologies, help you raise your game and increase your competitive edge.

Contents

Mechanical construction	4
AC FORM HMI	6
Generator	8
Autonomy and flexibility	10
GF Machining Solutions	18



Passion for Precision



Perfect results at your fingertips

The ergonomics of GF Machining Solutions' new AC FORM human-machine interface (HMI) put customers in the driver's seat by making die-sinking EDM an intuitive, easy-to-learn and easy-to-use process. That means greater autonomy over your processes, higher efficiency, improved process reliability and accelerated performance. The standardized working environment created by the AC FORM HMI makes it easy to achieve perfect machining results.

Mechanical construction

Compact and rigid mechanical concept

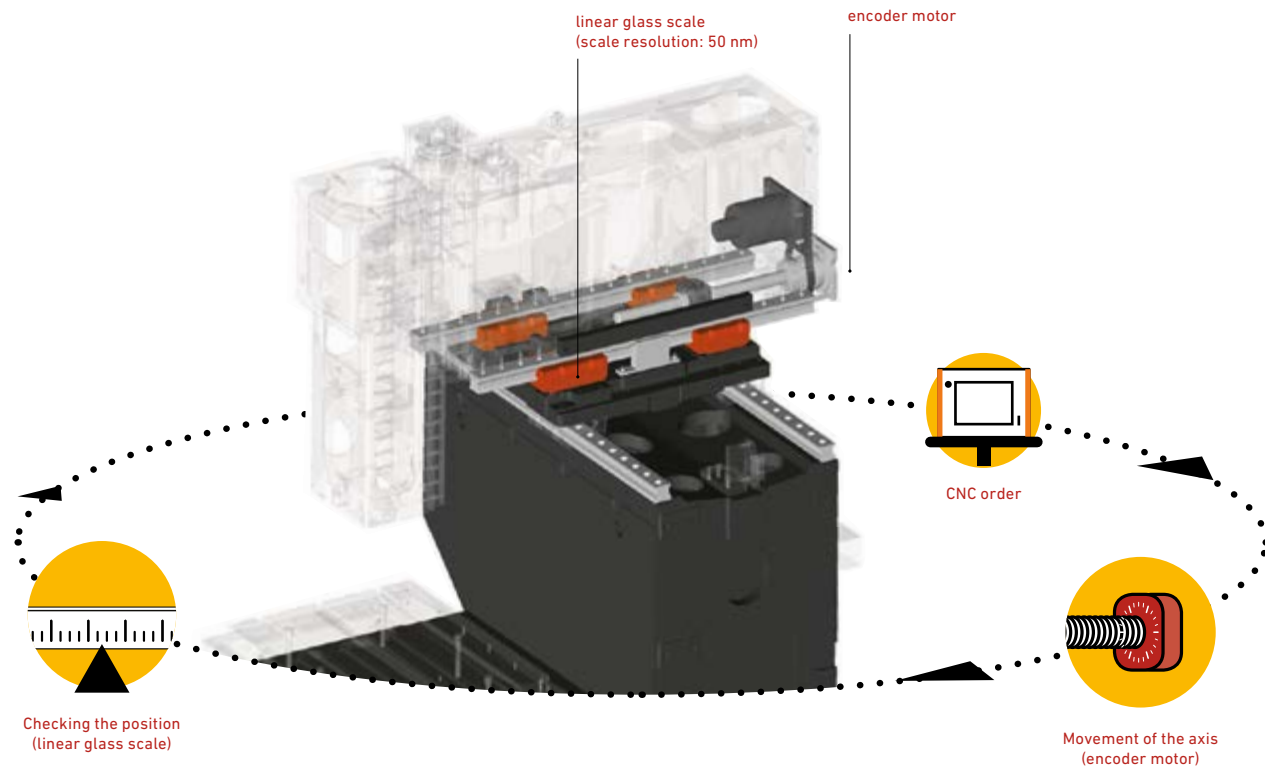

Robust mechanical concept

The construction as a short C frame and the oversized casting guarantee mechanical stability and precision throughout the life of the machine. The weight of the part and the volume of the dielectric have no effect. In addition, the robustness of the machine absorbs all the machining forces to maintain a precise gap between the part and the electrode.

Linear glass scales: lifetime accuracy

To obtain reliable positioning accuracy, only linear glass scales are effective. They eliminate all the classic errors, such as backlash, expansion and wear effects. The axis servo control system developed by GF Machining Solutions is a closed loop measurement solution designed to provide infallible accuracy, whatever the travel. It makes periodic maintenance and calibration operations unnecessary.

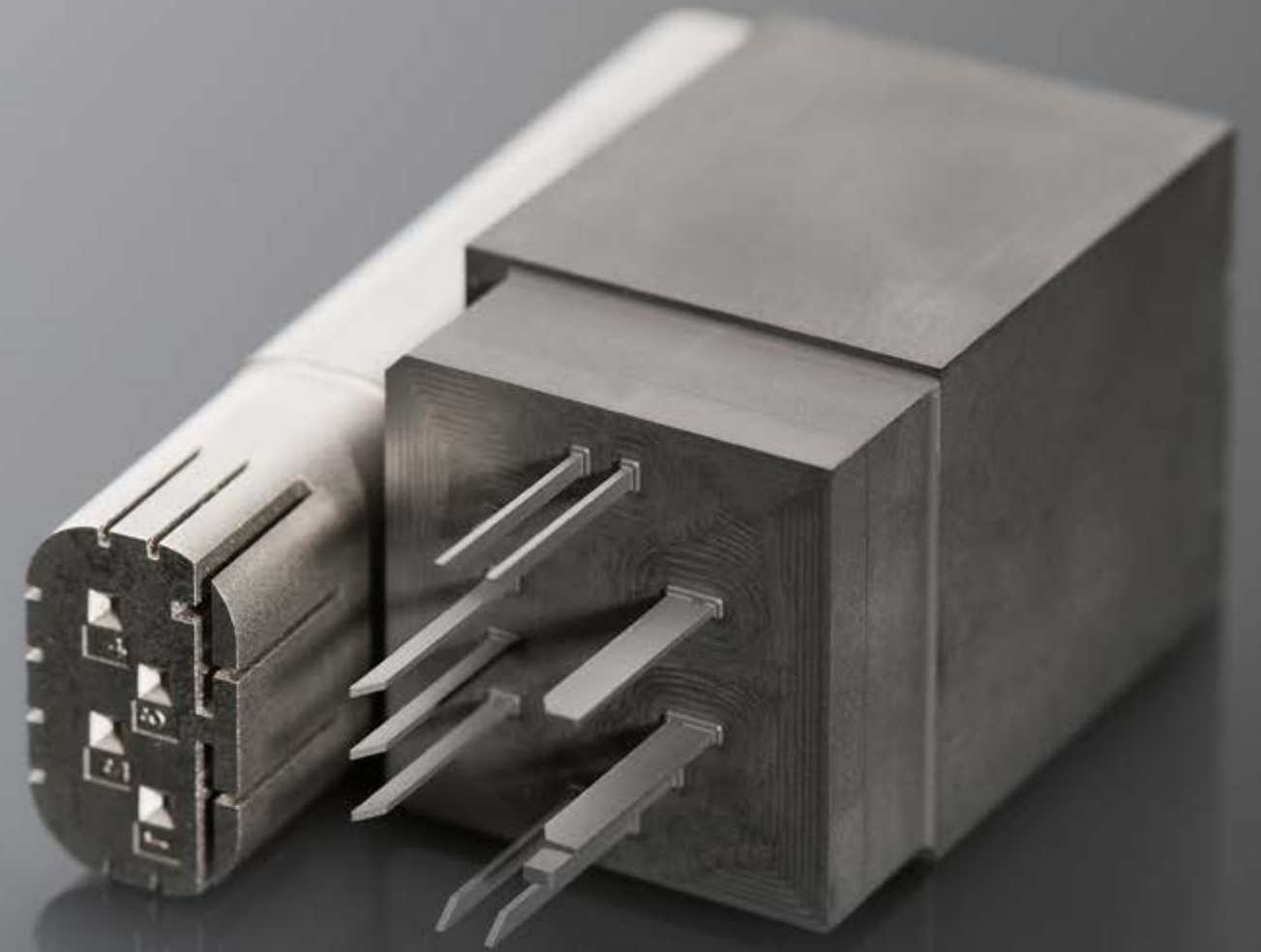

+ Exceptional efficiency

The FORM P 350, FORM P 600 and FORM P 900 combine productivity and flexibility



AC FORM HMI

Faster control, in complete security

Dynamic manufacturing process

The development of AC FORM human-machine interface (HMI) is based on a study carried out with numerous mold makers in order to streamline the mold-making technique. The organization and layout of screens are a direct development of the information taken from this study. This user-friendliness, which has made GF Machining Solutions interfaces so successful, has not only been maintained but has been developed even further to benefit the mold maker's task.

Maximize productive time

Due to the necessity of maximizing productive time, the AC FORM HMI brings new solutions:

- Part Express allows interruption of an operation so that an urgent job can be inserted.
- Job List organizes the order of jobs according to manufacturing priorities.

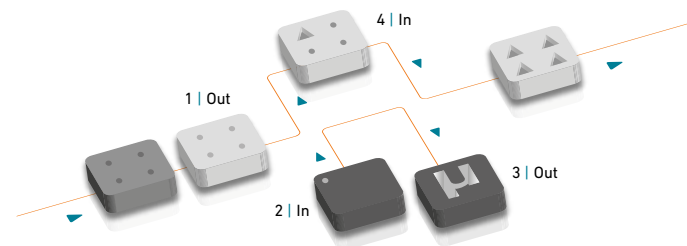

e-Doc

The FORM P 350/600/900 range incorporates new online help to allow the operator to find relevant information as quickly as possible. This occurs via simplified access to help menus, by having a clearly organized navigation interface, that is more user-friendly and easy to grasp, and including search by key words or user index. Machining examples are produced as hard copy, presented in a succinct manner.

They are called up by using the online help system, so that implementation of a machining process can be followed stage by stage. More than additional descriptive documentation, e-Doc allows a genuine knowledge transfer for the benefit of the operator, enabling him to improve his knowledge continuously, while reducing working days lost to training.

Automatic CAD/CAM link

The different EDM machining sequences are automatically integrated into AC FORM HMI.

Platform: Windows

- Integral PC
- Touch screen
- CD-ROM drive
- USB port
- Network connection



Flexible work organization

AC FORM HMI offers you job creation whether on the FORM P 350/600/900 machine or on a PC and allows you to organize them according to your priorities on the machine.

Measurement of essential offsets and positions

during work preparation: the measurements made on a pre-measurement terminal can be used directly by AC FORM HMI.

Electrodes designed under AC FORM HMI

offer ideal undersize and streamline the number of electrodes necessary for machining.

Machining under AC FORM HMI high surveillance

with Systems EXPERT automated protection, guarantees you results at the height of your requirements.

Control of work executed under AC FORM HMI

automatically creates a report after each machining session. The operator can access it via the network or directly on the machine.

SMS notification

All information related to machining can be transmitted directly to the operator via SMS.

Interactive graphical assistance

All operations, such as measurement, machining or cavity-positioning cycles, are illustrated by graphics/icons, allowing the operator to understand intuitively and spontaneously.

Measurement cycles

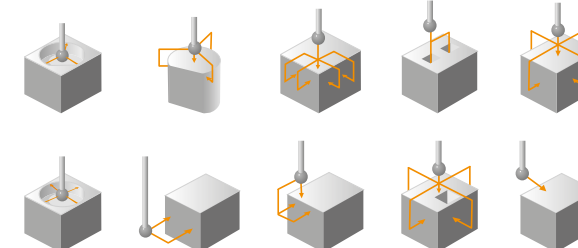

2D/3D machining cycles

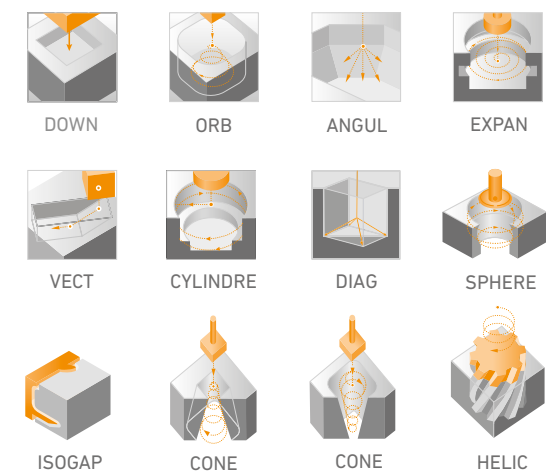

Generator

Flexibility and power guarantee reliable results

The FORM P 350, FORM P 600 and FORM P 900 sinker spark erosion machines are fitted with an Intelligent Speed Power Generator (ISPG) which, using patented technologies, establishes new standards in surface quality, material removal and accuracy of form. Electrode wear is reduced in all machining operations, from roughing to finishing, with copper or graphite electrodes. Productivity shows an average increase of 30 percent, and can even reach 100 percent for pre-milled forms. Even in the presence of deep, narrow cavities, with poor flushing conditions, a 50 percent increase in erosion speed can be obtained with no increase in electrode wear.

Predictive planetary erosion

With the Predictive Learning System (PLS), the erosion conditions for orbital movements are continuously recorded and analyzed. When there is a deviation, the planetary erosion process is thus optimized one step after the other. The cavities are then made quickly and accurately. [1]

Small, deep cavities

The High Velocity Pulsation (HVP) unit allows efficient cavity cleaning by rapid retraction with extreme reaction time and by smooth re-entry. The electrodes are moved rapidly during the return movement, with an extremely short reaction time, creating an action that yields good flushing conditions and, for small deep cavities, guarantees that optimum erosion results are obtained. [2]

Mastery of spark generators

The ISPG generator yields distinctly higher removal rates on average than other products, whether it is machining blades, conical shapes or pre-milled cavities, all of which are machining challenges that can be resolved only with electro erosion. [3]

Controlled process

Using perfected algorithms reacting more quickly, while organizing the electro erosion process safely even for Adaptive Current Control (ACC) and Adaptive Current Optimization (ACO) high removal rates, productivity is increased. [4]

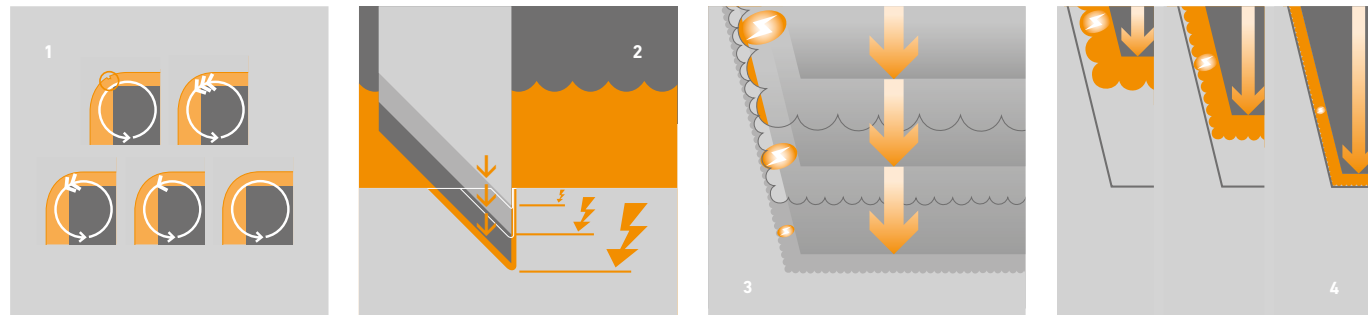

The surface finish quality

The SF module allows excellent surface finish qualities to be obtained notably during finish machining and this can be done with most conductive materials.



Large surfaces, no problem

Dynamic acceleration and adaptively controlled lift movements allow optimum erosion results, even with large areas, whereas electrode return movements stop uniformly.

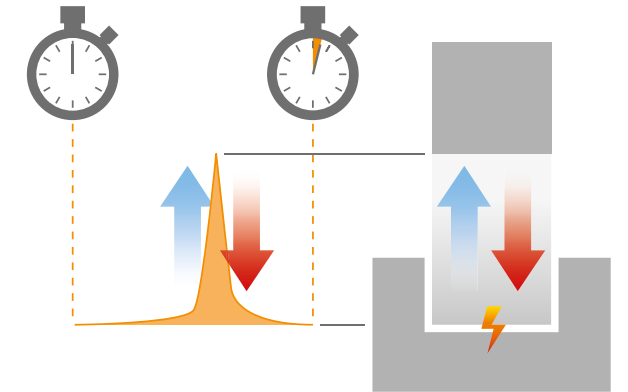

Lowest-wear EDM

The iQ (innovative Quality) technology developed by GF Machining Solutions is available for the FORM P 350, FORM P 600 and FORM P 900. The iQ technology allows wear-free EDM with graphite and copper electrodes, reducing the number of electrodes and corresponding costs and guaranteeing the highest accuracy of form.



Part material: Steel 1.2343
Electrode material: Graphite R8710
Number of electrodes: 2
Number of simple forms: 7
Machining depth: 9 mm
Roughness: VDI 19, Ra 0.9 µm
Electric discharge machining time: 88 minutes
Average linear wear: 7 µm



Part material: Steel 1.2343
Electrode material: Copper
Under measure: 0.56 mm
Machining depth: 20 mm
Roughness: VDI 26, Ra 1.8 µm
Result with iQ technology (total time): 5 h 21 min.
Reduction in wear: from 20% to 90%



Autonomy and flexibility

Configurable performance potential

High autonomy and reduction in dead time

The FORM P 350, FORM P 600 and FORM P 900 can be equipped with integrated tool changers, allowing them to work for long periods without surveillance. These linear changers allow satisfactory autonomy for work requiring a smaller number of tools.

Integrated tool changer (option)

The FORM P 900 can be equipped with a tool changer integrated into the machining zone to keep machine dimensions to a strict minimum. This changer is available with a capacity of 10 to 20 positions, installed on the left or right side of the machining zone.



Remote control menus adapted to operator tasks

To allow the operator to adapt the remote control to the manual task at hand, a menu is provided for configuring the icons displayed on the remote control display. In addition of standard icons, this menu allows the operator to define semi-automatic movements or specific measuring cycles during the manual process.

This is one of many AC FORM HMI features that put greater flexibility and efficiency at the operator's fingertips.



Get on the fast track to superior quality

GF Machining Solutions eTracking software platform, linked with the computer numerical control (CNC) of EDM machines, help trim costs by reducing the number of rejected parts and focusing on post-machining control of suspect parts. Our eTracking software helps you establish standard machining methodology from the start, lays a foundation for machining quality, and creates a data record for certification of quality production.



Renishaw probe

To ensure positioning precision, an optical transmission probe can be managed by the FORM P 350/600/900. Measurement allows dimensional inspection of machined cavities as well as the taking of references of the part, without having to remove it, thus saving a considerable amount of time. Furthermore, a measurement report is automatically generated by AC FORM HMI enabling rigorous checking and monitoring.



Accura-C, the best high-performance axis on the market

It is not unusual to be confronted by machining where the electrodes are incorrectly located, even by such a distance that maintaining their position or stability during machining becomes problematic. Pulsation-induced movements in a liquid (dielectric) medium generate lateral forces (flexural or rotational) on the electrode, which must be resisted by the C-axis. Thanks to its very robust design, the Accura-C allows very high moments of inertia to be absorbed, up to 5000 kgcm².

Autonomy and flexibility

Configurable performance potential

Increased autonomy without manual intervention

Manufacture of a mold often requires a large number of electrodes whose spark erosion time can vary noticeably from one cavity to another. The FORM P 350/600 machines have a new rotary changer which offer a large storage capacity for up to 160 electrodes. A double gripper clamp reduces unnecessary movements, notably speeding up the loading process.

Aim: 7,000 hours of EDM per year

Autonomous cell management maximizes machine time, which can now be increased from 2,500 hours on average, to close to 7,000 hours per year. Due to importing CAD/CAM data into the machine operator's AC FORM HMI, taking references, as well as optimizing tool changer cycles and flexible machining programming, results are backed up while allowing continuous production.

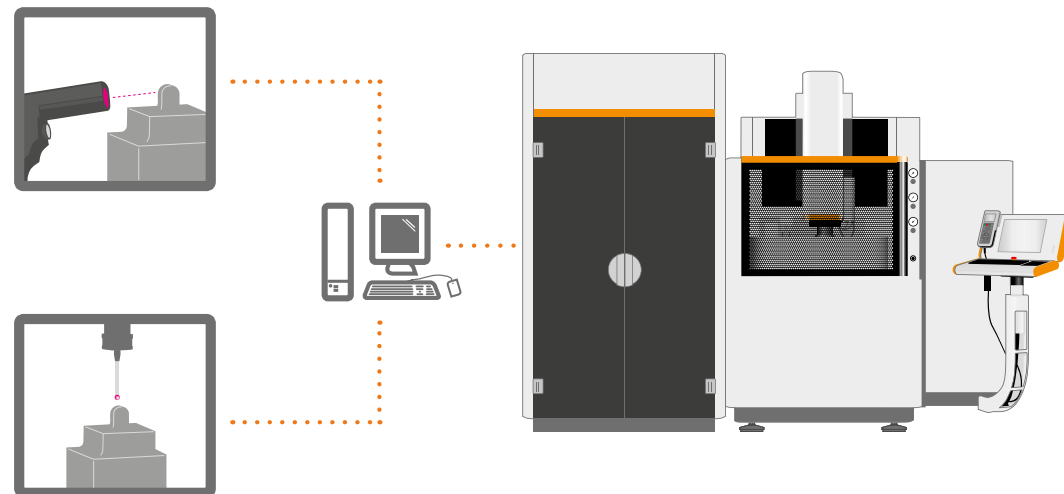

Record productivity

This cell-management system expands and supplements the practicality of AC FORM HMI. Quasi-total autonomy of each cell radically optimizes machine time while simultaneously increasing operator comfort and eliminating risk of errors. Workshop productivity beats all records.

Machining flexibility and reliability of work results

Thanks to AC FORM HMI's integral automation of machining sequences, as well as the design and functionality of Part Express, productive time is maximized, while still allowing urgent work to be inserted easily. End-to-end reliability of the process is assured.

Technical Data



FORM P 350



FORM P 600



FORM P 900

		FORM P 350	FORM P 600	FORM P 900
Machine				
Architecture		C-frame/Fixed table/Drop tank		
Dimensions (*)	mm (in)	1900 x 1690 x 2398 (74.80 x 66.53 x 94.4)	2265 x 2110 x 2780 (89.17 x 83.07 x 109.45)	2970 x 3100 x 3320 (116.93 x 122.05 x 130.71)
Total weight (without dielectric)	kg (lbs)	2800 (6173)	4500 (9920)	7000 (15432)
Floor space (**)	mm (in)	1900 x 1690 (74.80 x 66.53)	3040 x 2830 (119.68 x 111.42)	2970 x 3100 (116.93 x 122.05)
Complies with "Machines, Safety and Health" directive		89/392/CEE	89/392/CEE	89/392/CEE
Complies with "Electromagnetic Compatibility" directive		89/336/CEE	89/336/CEE	89/336/CEE
X, Y, Z axes				
X, Y, Z travel (*)	mm (in)	350 x 250 x 300 (13.78 x 9.84 x 11.81)	600 x 400 x 450 (23.62 x 15.75 x 17.72)	900 x 700 x 500 (35.43 x 27.56 x 19.68)
X, Y, axes speed	m/min (ft/min)	6 (19.7)	6 (19.7)	6 (19.7)
Z axis speed	m/min (ft/min)	15 (49.2)	10 (32.8)	7.5 (24.6)
Positioning resolution X, Y, Z	µm (in)	0.05 (0.000002)	0.05 (0.000002)	0.05 (0.000002)
Work area				
Worktank size (*)	mm (in)	790 x 530 x 350 (31.1 x 20.87 x 13.78)	1220 x 870 x 470 (48.03 x 34.25 x 18.50)	1814 x 1215 x 700 (71.42 x 47.83 x 27.56) Extendable in X
Worktable size (**)	mm (in)	500 x 400 (19.68 x 15.75)	750 x 600 (29.53 x 23.62)	1100 x 900 (43.31 x 35.43)
Distance floor to clamping level	mm (in)	1000 (39.37)	1000 (39.37)	1100 (43.31)
Min./Max. distance between table and chuck	mm (in)	150/450 (5.91/17.72)	150/600 (5.91/23.62)	322/822 (12.68/32.36)
Workpiece and electrode				
Max. electrode weight	kg (lbs)	50 (110.23)	50 (110.23)	50 (110.23)
Max. workpiece weight	kg (lbs)	500 (1102.31)	1600 (3527.40)	3000 (6613.86)
Max. workpiece dimensions (*)	mm (in)	790 x 530 x 275 (31.1 x 20.87 x 10.83)	1220 x 870 x 470 (48.03 x 34.25 x 18.50)	1814 x 1215 x 600 (71.42 x 47.83 x 23.62)
Bath level (programmable)	mm (in)	100 - 325 (3.94 - 12.8)	100 - 450 (3.94 - 17.72)	100 - 630 (3.94 - 24.80)

* Width x depth x height ** Width x depth

		FORM P 350	FORM P 600	FORM P 900
Dielectric unit				
Capacity	l (gal)	410 (108.65)	700 (184.8)	2500 (662.5)
Number of filter elements and type		4 Paper filter	6 Paper filter	8 Paper filter
Generator				
Generator type		ISPG	ISPG	ISPG
Max. machining current (option)	A	80 (140)	80 (140)	80 (140)
Best surface finish	µm Ra	0.08	0.08	0.1
Electrical supply Standard				
Standard voltage		3 x 380V/400V ± 10%. 50/60Hz (50Hz standard)		
Cooling				
Heat exchanger dielectricum/water for the dielectricum		Integrated	Integrated	Integrated
Control Unit				
Operating system		Windows		
Data input		15" LCD screen, mouse or touch screen, keyboard and Remote control		
User interface		AC FORM HMI		
Expert systems		TECFORM		
Console support		Movable on cabinet or on foot		
Modules				
Z axis (15 m/min)		Standard	—	Option
Linear tool changer (*)		4 (Std. tooling) 5 (Combi tooling)	6 (Std. tooling) 6 (Combi tooling)	10 (Std. tooling) Left 10 (Std. tooling) Right
Rotary tool changer (*)		16-80 pos. (Std. tooling) 32-160 pos. (Combi tooling)	16-80 pos. (Std. tooling) 32-160 pos. (Combi tooling)	— —
Flushing Injections		2 Laterals, 1 through the piece, 1 through the electrode, 1 suction		
Heat exchanger air/water for the cabinet		Option	Option	Option
Multicavity flushing 6 outputs		Option	Option	Option
3D probe measuring system for Erowa or System 3R		Option	Option	Option
iQ graphite and copper module for reduction of electrodes' wear		Standard	Standard	Standard
Standard C-Axis (*)				
Max. electrode weight on automatic chuck	kg (lbs)	50 (110.23)	50 (110.23)	50 (110.23)
Rotation speed	rpm	0-100	0-100	0-100
Max. inertia	kgcm ² (lbsin ²)	2000 (683)	2000 (683)	2000 (683)
Accura C-Axis (*)				
Max. electrode weight on automatic chuck	kg (lbs)	50 (110.23)	50 (110.23)	50 (110.23)
Rotation speed	rpm	0-100	0-100	0-100
Max. inertia	kgcm ² (lbsin ²)	5000 (1700)	5000 (1700)	5000 (1700)

* Option

FORM P 350

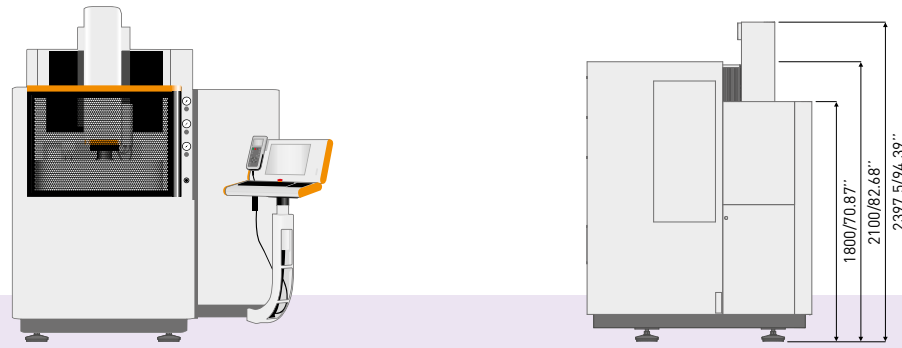

FORM P 900

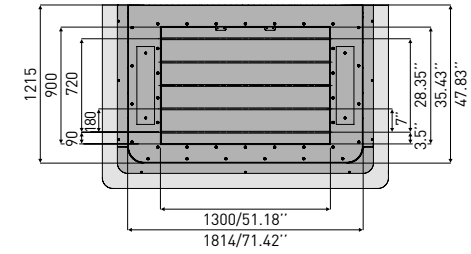
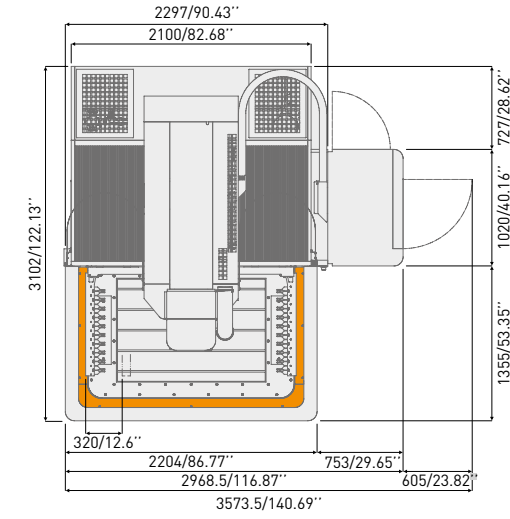
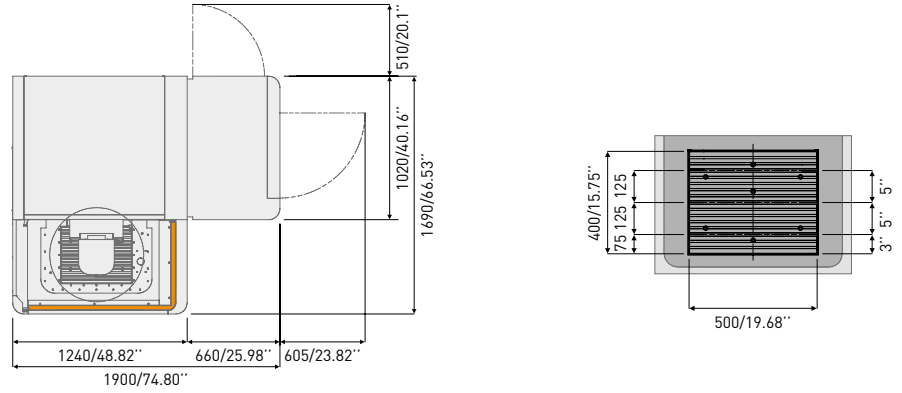
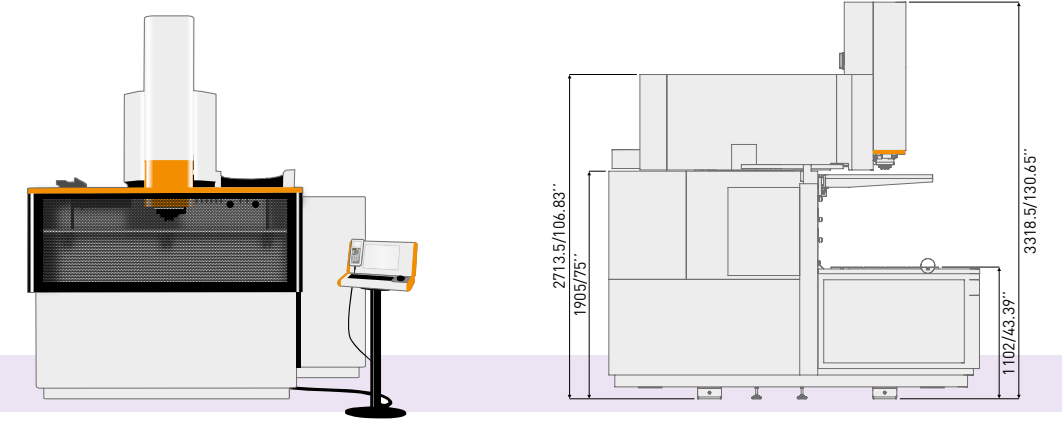

FORM P 600

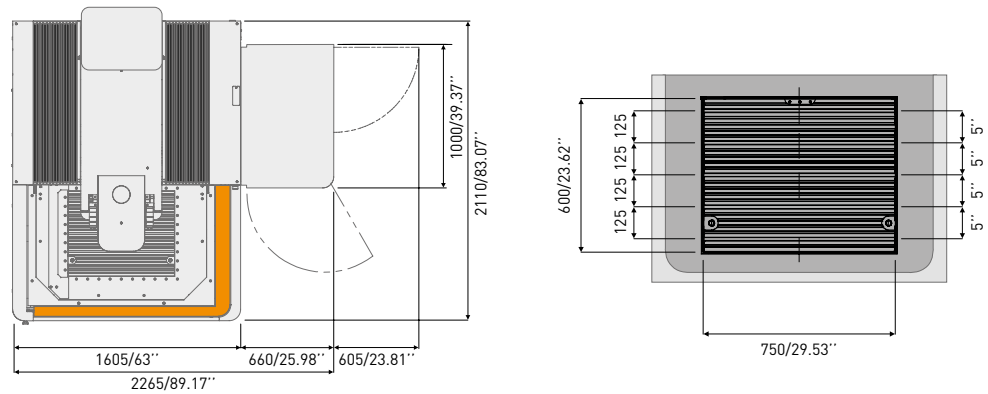
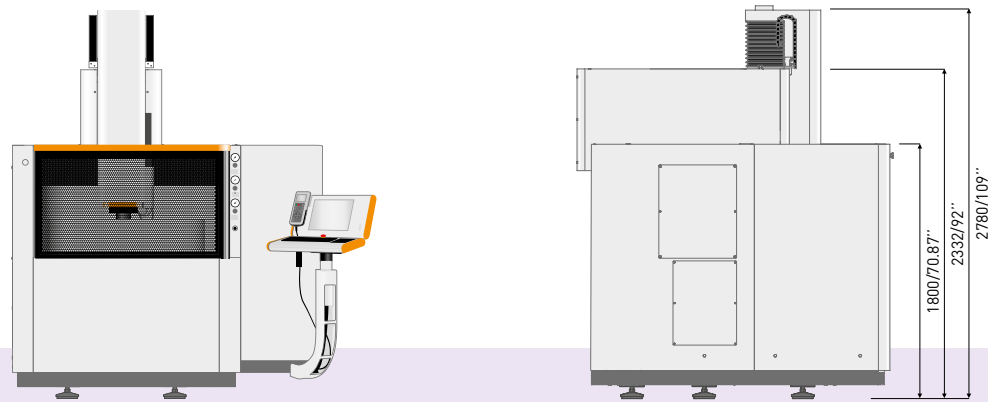

GF Machining Solutions



EDM (electrical discharge machining)

AgieCharmilles wire-cutting, die-sinking and hole-drilling machines

For over 60 years we have been at the forefront of every EDM development: designing and refining the EDM process and building machine tools that deliver peerless part accuracies, surface finishes, cutting speeds and process reliability. Today, our AgieCharmilles wire-cutting, die-sinking and hole-drilling machines are recognized throughout the world as the best in the business. Our continuous research and development in digital generator technology, control systems and integrated Automation systems are evidence of our commitment to keeping your EDM operations on the leading edge of technology.



Laser

AgieCharmilles Laser texturing machines

Laser texturing is a fully-digitized surface engineering process that has huge potential. The technology enables precise 2D and 3D textures or engravings to be machined accurately and directly onto complex parts or molds to improve and alter their aesthetic appeal, functionality and performance. The process is infinitely repeatable and offers many distinct environmental and economic advantages over conventional texturing processes.

Laser Additive Manufacturing (AM)

GF Machining Solutions has partnered with EOS, the global leader for high-end AM solutions, to integrate this innovative technology and further develop it into its current solutions to fully benefit the mold industry, by focusing on injection efficiency: optimized cooling design to reduce cycle time, lower energy consumption, higher quality of plastic parts.



Tooling and Automation

System 3R Tooling, Automation and software

Productivity is the key to manufacturing success, and automating a manufacturing process is a proven method of increasing its efficiency, effectiveness, quality and reliability. System 3R's integrated Tooling, Automation and software solutions ranging from simple workpiece pallet and electrode changers through to flexible manufacturing and robot handling systems are guaranteed to help you increase their competitive advantage.



Milling

Mikron high-speed (HSM), high-performance (HPM) and high-efficiency (HEM) Milling centers

Customers operating in the mold, tool and die and precision component manufacturing sectors stake their reputations on being able to quickly and cost-competitively meet their customers' demands. That's why they invest in GF Mikron machines. Incorporating the latest and most advanced technologies and premium-performance components, Mikron HSM, HPM and HEM machines help you increase your production capabilities and improve your productivity. Designed and built for speed, accuracy and reliability, the machines, like you, are proven performers.

Liechti dedicated aerospace and energy machining centers

Aerospace and power generation turbine manufacturers increasingly turn to Liechti dedicated five- and six-axis machining centers to machine complex, high-precision airfoils on blades, disks, blings, blisks/IBRs and impellers. It's easy to see why because these machines, with their specific profile machining technology, specialized CAD/CAM software and engineering competence for ultra-dynamic machining in titanium, Inconel, nimonic, titanium-aluminide and high-alloy steels, yield productivity gains as much as 30 percent, thanks to reduced machining times. In the globally competitive aerospace and power generation manufacturing sector, that's definitely worth shouting about.

Step-Tec Spindles

At the heart of every GF Mikron machining center is high-performance Step-Tec Spindle. Step-Tec Spindles are essential core components of our machining centers. Highly accurate and thermally stable Step-Tec Spindles ensure that our machines can handle everything from heavy-duty roughing to fine-finishing operations.



Customer Services

Operations Support, Machine Support and Business Support

To help you get the most and the best from your machine tools and equipment, we offer three levels of support. Operations Support covers our range of original wear parts and certified consumables (EDM wires, filters, resins, electrodes etc.) to ensure that your machines are performing at the highest levels. Machine Support maximizes, through our best-in-class technical support, preventive services and quality spare parts, your machine tool uptime. Business Support is designed to help you make a real step-change in your productivity and performance with solutions tailored to your specific needs.



At a glance

We enable our customers to run their businesses efficiently and effectively by offering innovative Milling, EDM, Laser, Additive Manufacturing, Spindle, Tooling and Automation solutions. A comprehensive package of Customer Services completes our proposition.

www.gfms.com

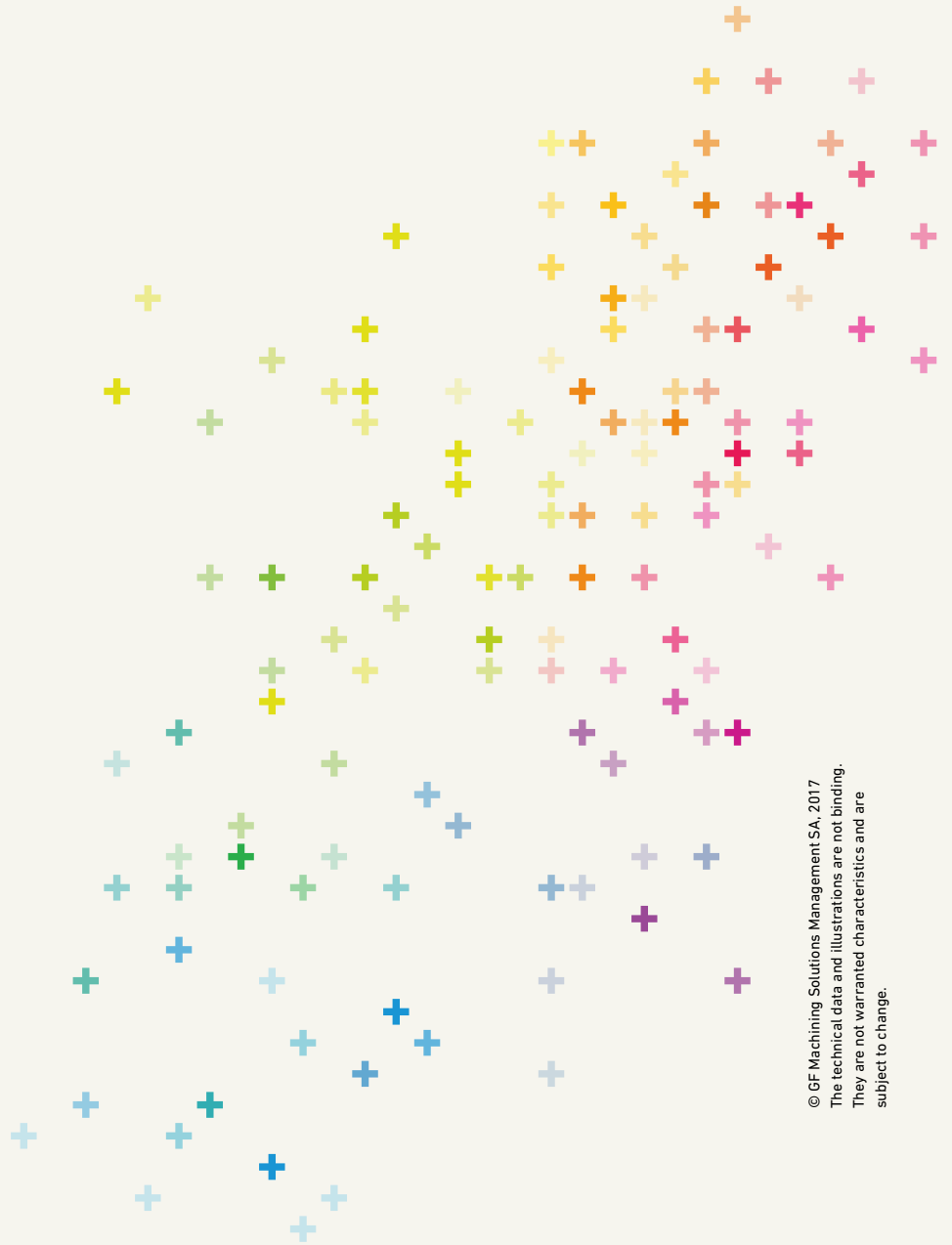

© GF Machining Solutions Management SA, 2017
The technical data and illustrations are not binding.
They are not warranted characteristics and are subject to change.