

Mikron

MILL S 400

MILL S 400 U

MILL S 500



GF Machining Solutions: all about you

When all you need is everything, it's good to know that there is one company that you can count on to deliver complete solutions and services. From world-class Milling, electrical discharge machines (EDM) and Laser texturing machine tools through to first-class Automation, Tooling and software systems—all backed by unrivaled Customer service and support—we, through our Mikron, Liechti, AgieCharmilles and System 3R technologies help you raise your game and increase your competitive edge.

Swiss design and quality

Content

Applications	4
Highlights	6
Static and dynamic accuracy	8
Thermal accuracy	9
High-tech motor Spindle	10
Table variations	11
ITM: the breakthrough in workpiece measurement	14
Automation	15
Tool magazine	16
Chip and dust management	17
Options	18
smart machine	19
Technical data	20
GF Machining Solutions	22



For more than 15 years, GF Machining Solutions has been pioneering the High Speed Milling technology with its Mikron machines. The MILL S series is the result of this continuous development and brings together the utmost features that make it the reference solution within the industry.

The MILL S 400 and MILL S 500 as well as MILL S 400 U are, respectively, 3-axis and 5-axis sensational High Speed Milling solutions for mold and die manufacturers. From automotive to ICT, through packaging and electrical components, these solutions serve manufacturers looking for high accuracy tools, highly repeatable multi-cavity molds, perfect surface quality expected as finished. Its "Plus" delivering all this at unbeaten productivity thanks to its machining speed and integrated Automation.

Applications

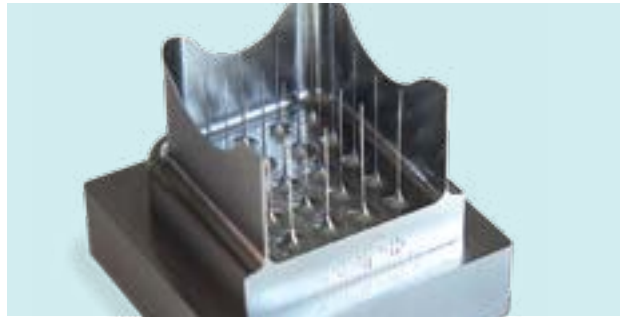

Pins

- Steel NimaxUddeholm / 40-45 HRC
- + Delicate geometries D0.1x16mm
- + High surface quality Ra 0.1 µm
- + Smallest workpieces



Mold insert

- Tempered steel 61 HRC 1.2379
- Construction of molds and workpieces
- + Highest surface quality Ra 0.05 µm
- + High metal removal rate Q=1.215 cm³/min
- + Highest accuracy when measuring the workpieces thanks to ITM

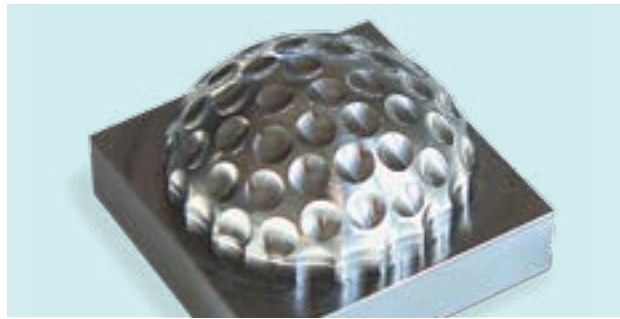

Reflector

- Böhler M333 50 HRC
- Automotive
- + Highest dimensional accuracy
- + High surface quality Ra 0.1 µm
- + Most precise track control using OSS extreme

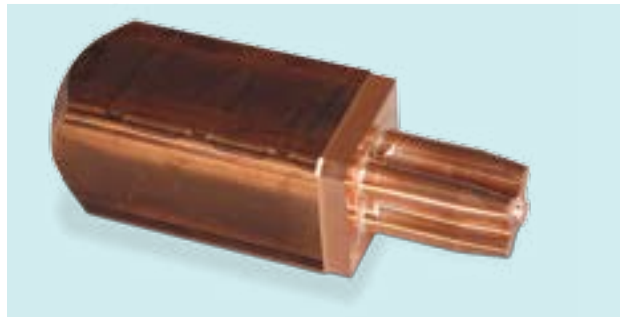

Electrode

- Copper E-Cu 58
- Watches and jewelry
- + Highest dimensional accuracy +/-0.004mm
- + Five-axis simultaneous processing



Graphite electrode

- Graphite
- Mold making
- + High contour accuracy
- + Efficient graphite processing



Five-axis simultaneous processing of mold inserts

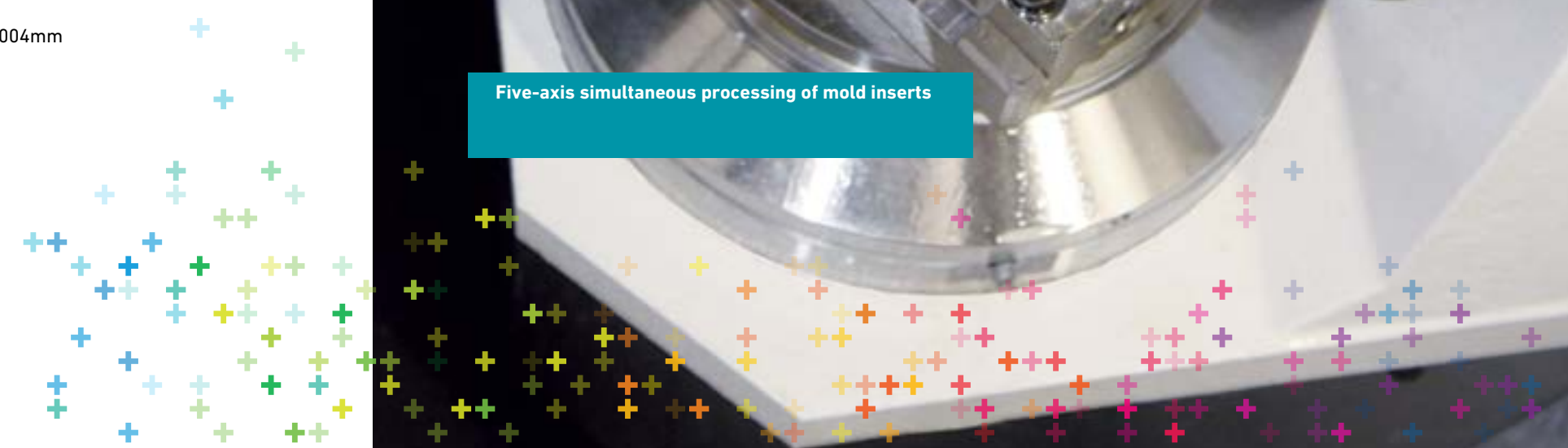

Highlights

Precision and quality for workpiece and mold making as well as production of precise parts

Mikron MILL S 400 U



Stability and dampening

The most important conditions for the highest dynamics, the best workpiece surface quality and precision include the dampening and stability of the machine foundation.

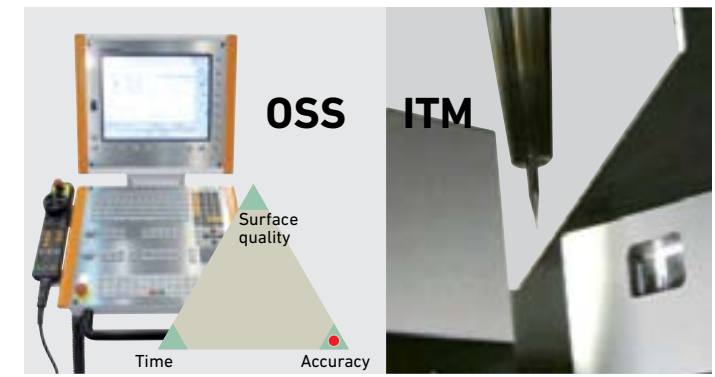

User friendly

The user friendliness of a machining center starts with the control. GF Machining Solutions supplements the Heidenhain control with high-performance smart machine modules such as:

- + OSS extreme: Process optimization the easy way
- + ITM: Precision and reliability in the measuring process

Accessible

The compact construction provides extraordinary accessibility to all relevant areas of the machining center.

- + Small installation footprint
- + Fast part setup
- + Best accessibility, also for maintenance

HSM inside

The axes are powered with linear drives for the highest speed and acceleration. The pyramid-shaped structure made of polymer concrete and the weight-optimized construction and rigidity are essential for the high-speed cutting (HSM) process.

Stable

The machine bed made of polymer concrete results in high thermal inertia as well as excellent dampening properties.

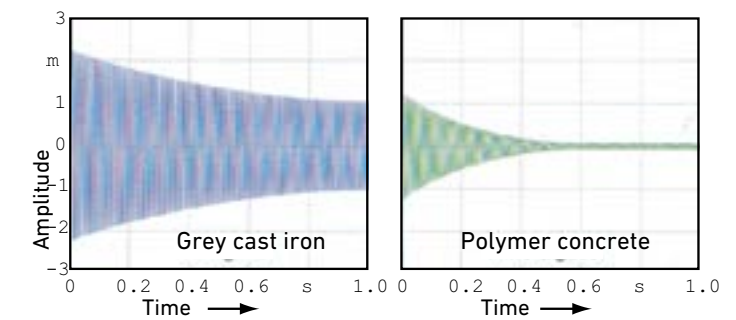

Optimal cooling

All power components are cooled optimally. Through the optional cooling of the machine bed, the thermal stability related to temperature fluctuations in the production environment of the machine is also significantly improved.

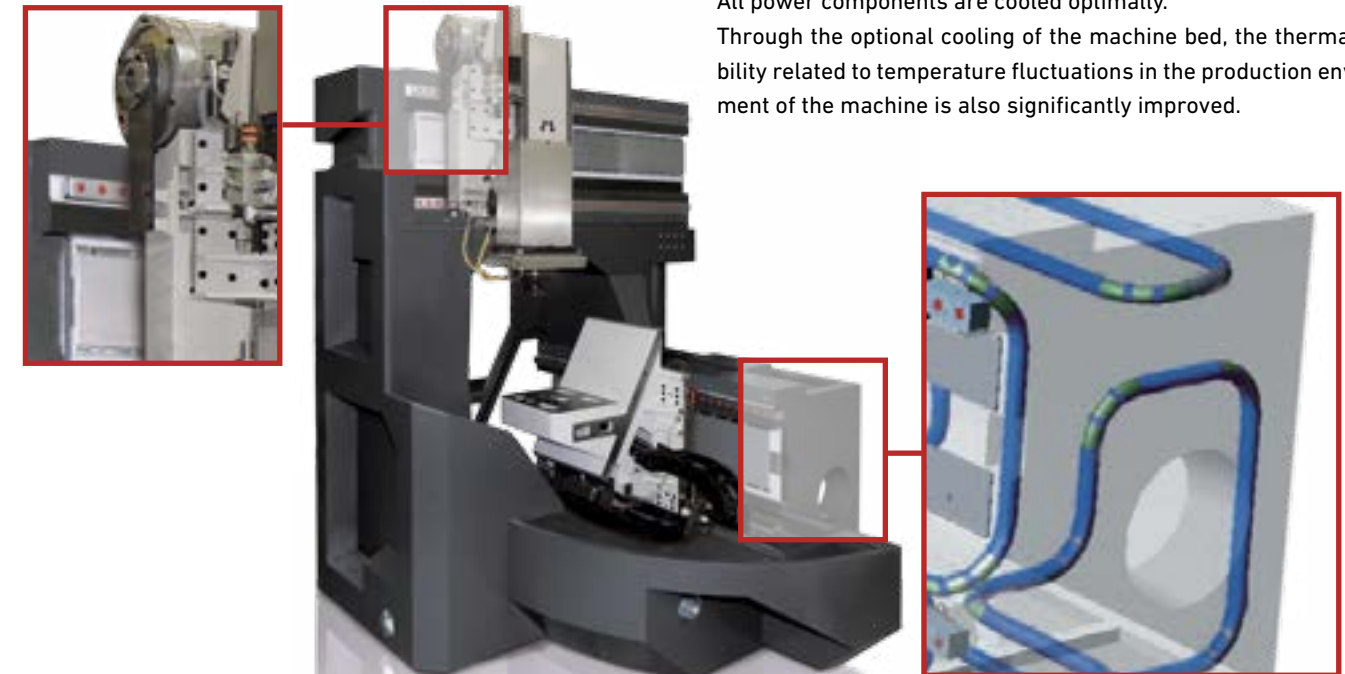

Accuracy

HSM core components: Static and dynamic accuracy

Static accuracy

Swiss precision

Before delivery, every Mikron MILL S machine is subjected to an extensive quality control process according to GF Machining Solutions approval guidelines in our air-conditioned production facility.

Quality awareness means added value.

Dynamic accuracy

Position sensor systems

All Mikron MILL S machines are equipped with direct sensor systems in the linear and rotary axes.

- + Proven Heidenhain accuracy
- + Resolution in nanometer range
- + Protected with air purge system

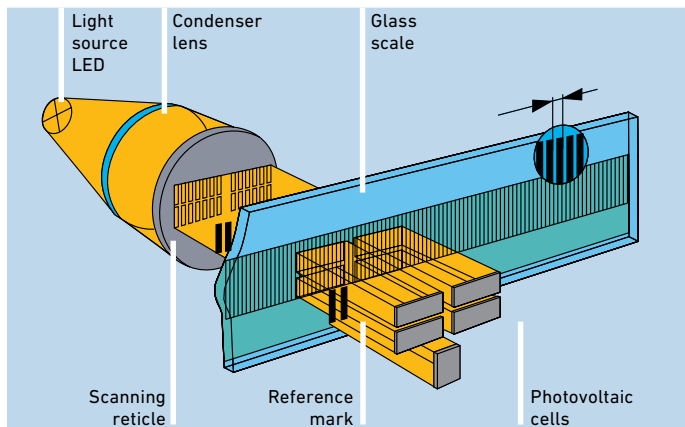
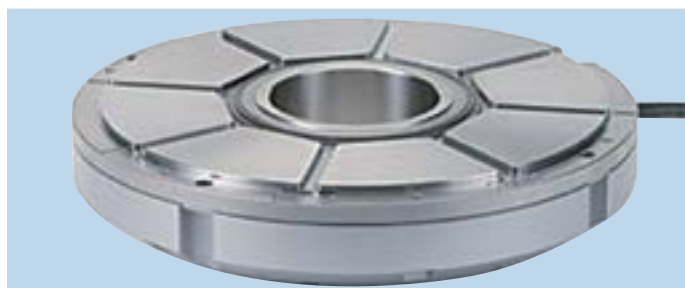

Accuracy

HSM core components: Thermal accuracy

Thermal accuracy

Cooling concept

The Mikron MILL S series leads precision machining into a new era. Since high axis feed rates over long periods always generate heat in the drive components, the Mikron MILL S series has a sophisticated cooling management system.

Each of the linear axes as well as the rotary unit has a separate cooling circuit. The heat is consistently transferred out of the machine and not distributed further inside the machine. This results in geometric stability which, in turn, ensures extremely high repeat accuracy of the motion control.

In Mikron MILL S machines, all electric heat sources are water cooled.

- + X, Y, Z, B, C drives
- + Spindle with Opticool technology
- + Electric cabinet

Spindle

Even higher accuracy with Step-Tec Opticool technology.

- + Cooling of the front roller bearings
- + Low transfer of heat in the workpiece interface
- + Increases accuracy when working with measuring probe on the machine

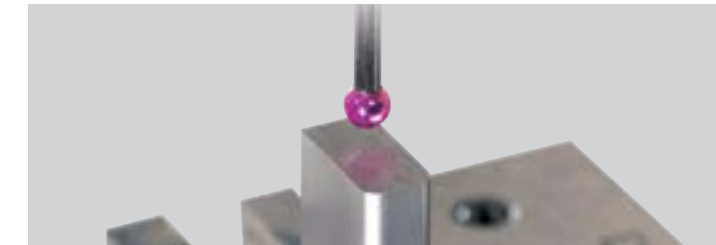
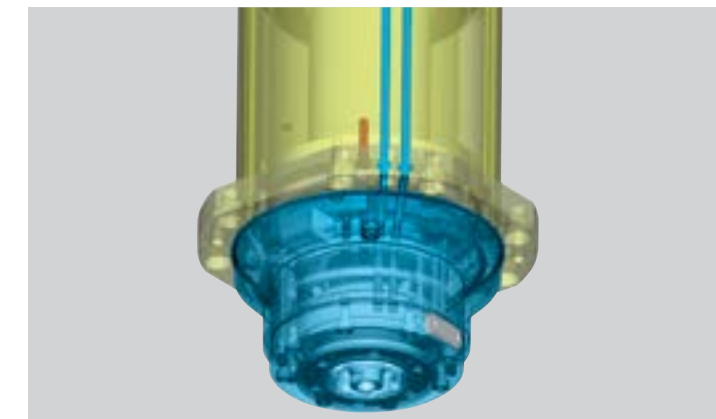

Five separate cooling circuits



Liquid-cooled primary and secondary part



Measuring probes

Even higher accuracy with new Thermo-Lock measuring probe technology.

- + Easy to install
- + Slows down the transfer of heat between measuring probe and tool Spindle
- + Increases accuracy when working with measuring probe on the machine
- + A strong duo: Thermo-Lock and Opticool

Spindle

Hightech Motor Spindle from Step-Tec



Spindles for demanding processing tasks

Whichever machine configuration you choose, with a Mikron MILL S machine you will also receive state-of-the-art Spindle technology.

The facts

- + Vector control for full torque in the lowest range
- + Highly stable ceramic hybrid Spindle bearing
- + Spindle jacket cooling using controlled cooling agent circuit for constant temperatures during the entire processing time
- + Oil/air lubrication system with extraction of used oil
- + Integrated "smart machine" sensors
- + Cooling between tool interface and front Spindle bearing with the Opticool Spindles

Your benefits

- + Precise high performance
- + Shorter acceleration phases
- + High torque
- + Thread cutting without compensation chuck up to M14 (CK45 to M8)
- + Drilling up to Ø 12 mm

Included in delivery is the smart machine module Advanced Processing System (APS) for the reliable recording and display of vibrations during the Milling process.

	30'000 min ⁻¹ HSK-E40 Opticool	42'000 min ⁻¹ HSK-E40 Opticool	42'000 min ⁻¹ HSK-E40 Cool Core	60'000 min ⁻¹ HSK-E32 Opticool
Mikron MILL S 400	+	+	+	+
Mikron MILL S 400 U	+	+	+	+
Mikron MILL S 500	+	+	+	+

- + Higher accuracy with Step-Tec Opticool technology
- + Cooling of the front roller bearings
- + Low transfer of heat in the workpiece interface
- + Also increases accuracy when working with measuring probe
- + Additional cooling of the rotor with separate cooling unit

Step-Tec Spindles

Since 1995, Step-Tec has been developing, producing, selling and repairing precise high-performance Spindles for leading manufacturers of machining centers for milling and drilling applications.



Table variations

As flexible as needed

Three-axis models

Avoid unproductive times

Completely integrated zero-point clamping systems from the manufacturers System 3R and Erowa.

Mikron MILL S 500

200 kg



Mikron MILL S 400

120 kg

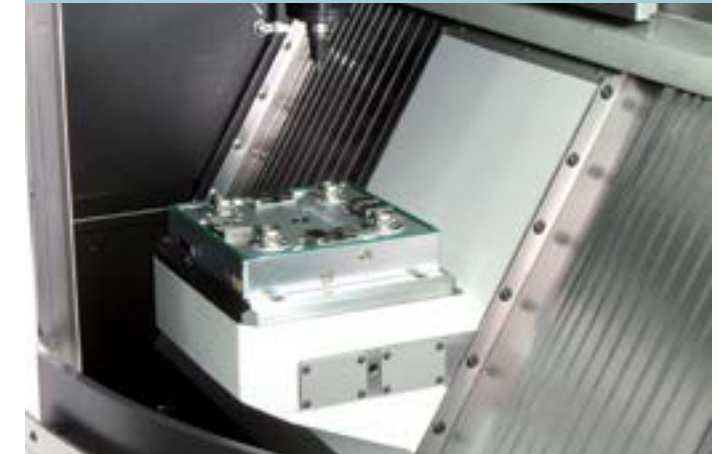

- Mikron MILL S 400 with clamping chuck
- + System 3R Dynafix
 - + System 3R GPS
 - + Erowa UPC

5-axis models

- + Extremely dynamic and fast:
Rotating and swiveling with direct drives in B and C axes up to 250 min⁻¹
- + Extremely accurate and precise:
Liquid-cooled motors and absolute measuring systems
- + Extremely stable and flexible:
Hydraulic clamping in the rotatory and swiveling axis plus integrated zero-point clamping system with a B axis swivel range of 220°

- Rotary swivel table with clamping chuck
- + System 3R Macro Magnum
 - + Erowa ITS

Mikron MILL S 400 U

25 kg



Machining of molds and workpieces

ITM (Intelligent Tool Measurement)

ITM: the breakthrough in cutting tool measuring

Intelligent Tool Measurement (ITM)

The ITM cutting tool measuring system records the complete tool tip up to \varnothing 12 mm on modern image sensors.

The digitally recorded cutting tool geometry is digitally cleaned and measured using special software. The idea becomes a reality: For the first time, ITM makes possible cutting tool measuring on a Mikron machine with a repeat accuracy in the micrometer range - even after the machining process.

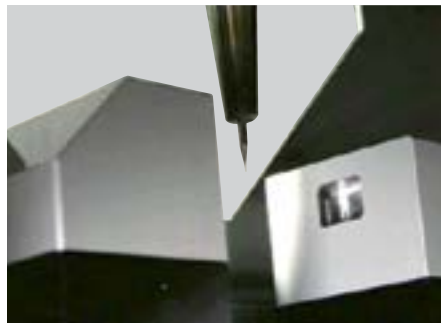

Detection of adhesive foreign particles

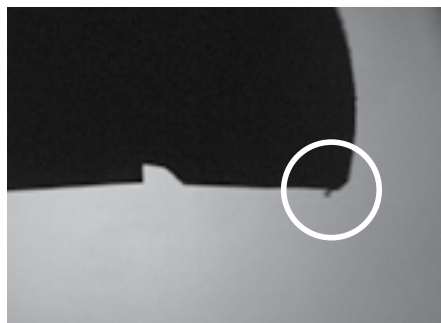



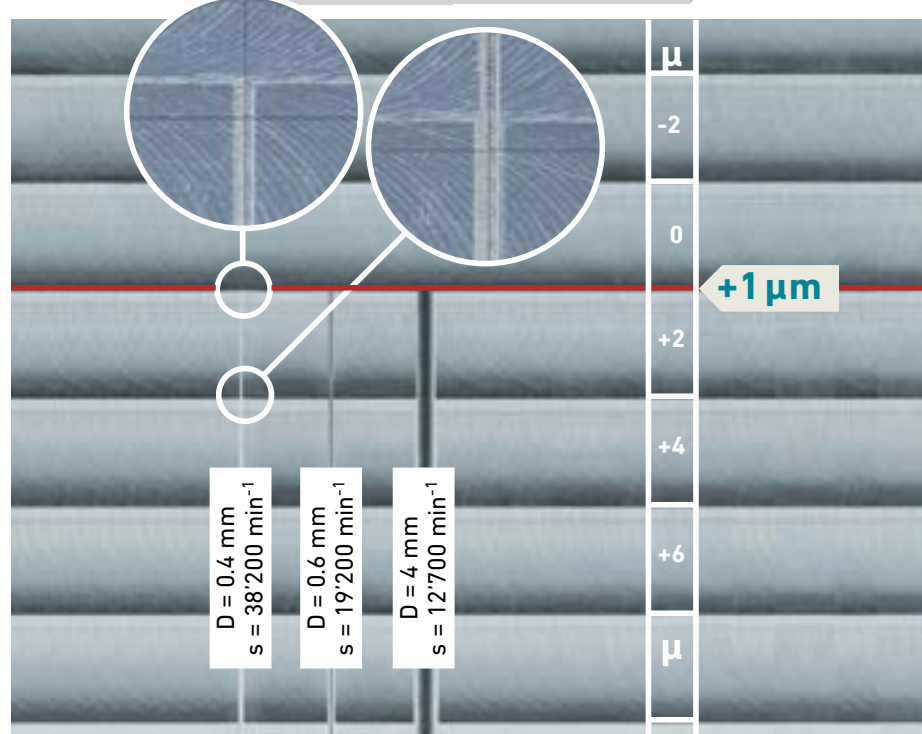
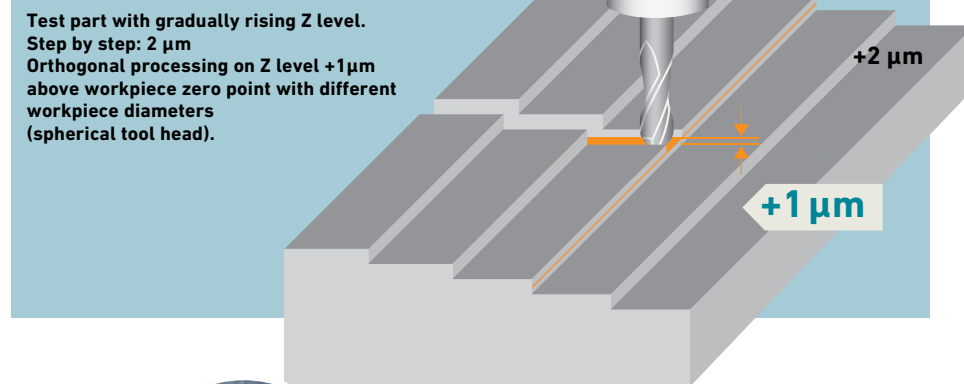
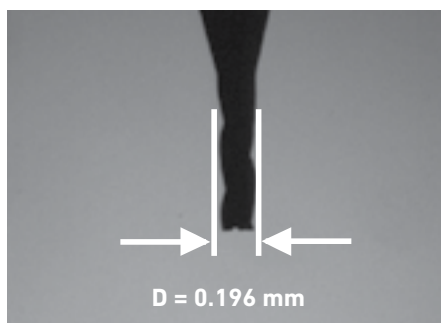



Measurement of smallest diameters

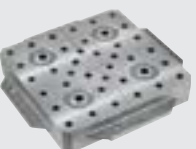

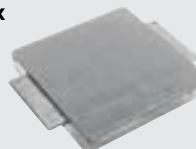
Automation

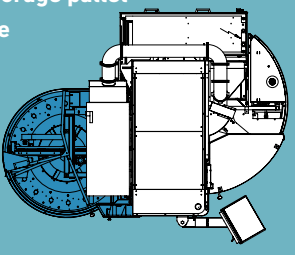
Produce more parts in less time at lower costs

Axis travel X, Y, Z: 500 x 450 x 360 mm	Three-axis models Mikron MILL S 400 90 kg	Five-axis models Mikron MILL S 400 U 25 kg
<p>The pallet magazine is an important plus</p> <p>Taking customer requirements into account, GF Machining Solutions has developed its own compact pallet magazines.</p> <p>The round storage and linear storage pallet magazines can be loaded during operation, and the CNC control is easy to operate.</p>	<p>System 3R GPS 240 x 240 mm</p> <p>10x</p> 	<p>System 3R Macro Magnum \varnothing 156 mm</p> <p>18x</p> 
	<p>System 3R Dynafix 280 x 280 mm</p> <p>7x</p> 	<p>Erowa ITS \varnothing 148 mm</p> <p>20x</p> 
	<p>System 3R Dynafix 350 x 350 mm</p> <p>7x</p> 	<p>Round storage pallet magazine</p> 
	<p>Erowa UCP 320 x 320 mm</p> <p>7x</p> 	

Automation interface

Thanks to a standardized robot interface, the Mikron MILL S series can be operated with robot systems from well known suppliers.

Regardless of the handling system is used, the machine offers comfortable accessibility when machines are linked to each other.



Tool magazine

Individual solutions, tailored for your production needs

Tool Automation in every expansion stage

- + Single- or double-row disk magazine
- + Reliable "pick-up" changing system
- + Feed monitoring using light beam
- + Capacity of up to 68 tools with magazines integrated in the basic machine
- + Alignment of the measuring probe

Optionally available with a variety of capacities:

- Mikron MILL S 400
- Mikron MILL S 400 U
- Mikron MILL S 500
- HSK-E40: 18; 36; 68, 168, 308 tools
- HSK-E32: 20; 40 tools

User-friendly loading of workpieces

- Productivity and process reliability are guaranteed thanks to the workpiece loading on the side
- + Simultaneous processing and loading
 - + Easy feed monitoring due to large glass window
 - + Ergonomic access



HSK E40 magazine with two rows, integrated in the basic machine, with a capacity of 68 workpieces.

Chip and dust management

Clean workspace

System models

The form and volume of the chips are determined by the machined material as well as the processing strategy. The options offered range from an colant tank with chip flushing to models with cooling oil and colant temperature stabilization...



...to an lift up chip conveyor with a spiral conveyor.



To increase the tank capacity, an external filter system with a capacity of 650l is available.



Graphite extraction using a powerful suction system



Custom-tailored systems



Chip rinsing



Coolant tank



Spiral conveyor



Chip conveyor to remove large volumes of chips



Cooling lubricant filtration



Cooling oil packing with temperature stabilization



Oil mist lubrication



Mist extraction



Mist extraction



Automation interface (closed)



Automation interface (open)



Measuring probes TI

- APS
- CAMplete
- Econowatt
- SIGMA FMC
- ITC
- ITC 5X
- ITM
- OSS
- OSS extended
- OSS extreme
- PFP
- RNS

smart machine
(www.gfac.com)

Additional options:

- + Rotating window
- + Dust extraction
- + Beacon
- + Laser measuring system
- + ITM (Intelligent Tool Measurement)
- +

The new dimension in modern production

Bringing intelligence into the milling process is the intended aim of "smart machine".

This includes a range of modules that are collectively referred to under the generic term "smart machine" and that fulfil various functions. In order to make the milling process "intelligent", various requirements have to be implemented. First of all, establishing comprehensive communication between man and machine, which makes precise information that the operator requires to assess the milling process available to him. Secondly, supporting the operator in the optimisation of the process, which considerably improves the performance. Thirdly, the machine optimises the milling process, which improves the process safety and the quality of the workpiece - above all in unmanned operation.

The facts

- + Greater accuracy in shorter machining times
- + Increase in the workpiece surface quality as well as the surface and shape accuracy
- + Recognition of critical machining strategies
- + Improvement in the process safety
- + Reduction of the machine set due to longer service life
- + Higher availability
- + Better operating comfort
- + Considerable increase in reliability in unmanned operation

smart machine construction kit system

Each of the modules fulfils a specific task. Just like in a construction kit, the user can select the modules that seem to him to be the best option for improving his process.

Your benefit

Producing the workpieces in a process-secure and precise manner, increasing the reliability in unmanned operation, increasing the service life of the machine and significantly reducing production costs.



Saving energy

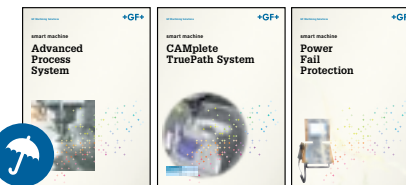

Protection



Precision



Productivity

The smart machine is constantly being further developed.

The currently available modules can be found at www.gfms.com

Technical data



Mikron MILL S 400 / MILL S 400 U / MILL S 500

Standard chip conveyor and belt filter unit

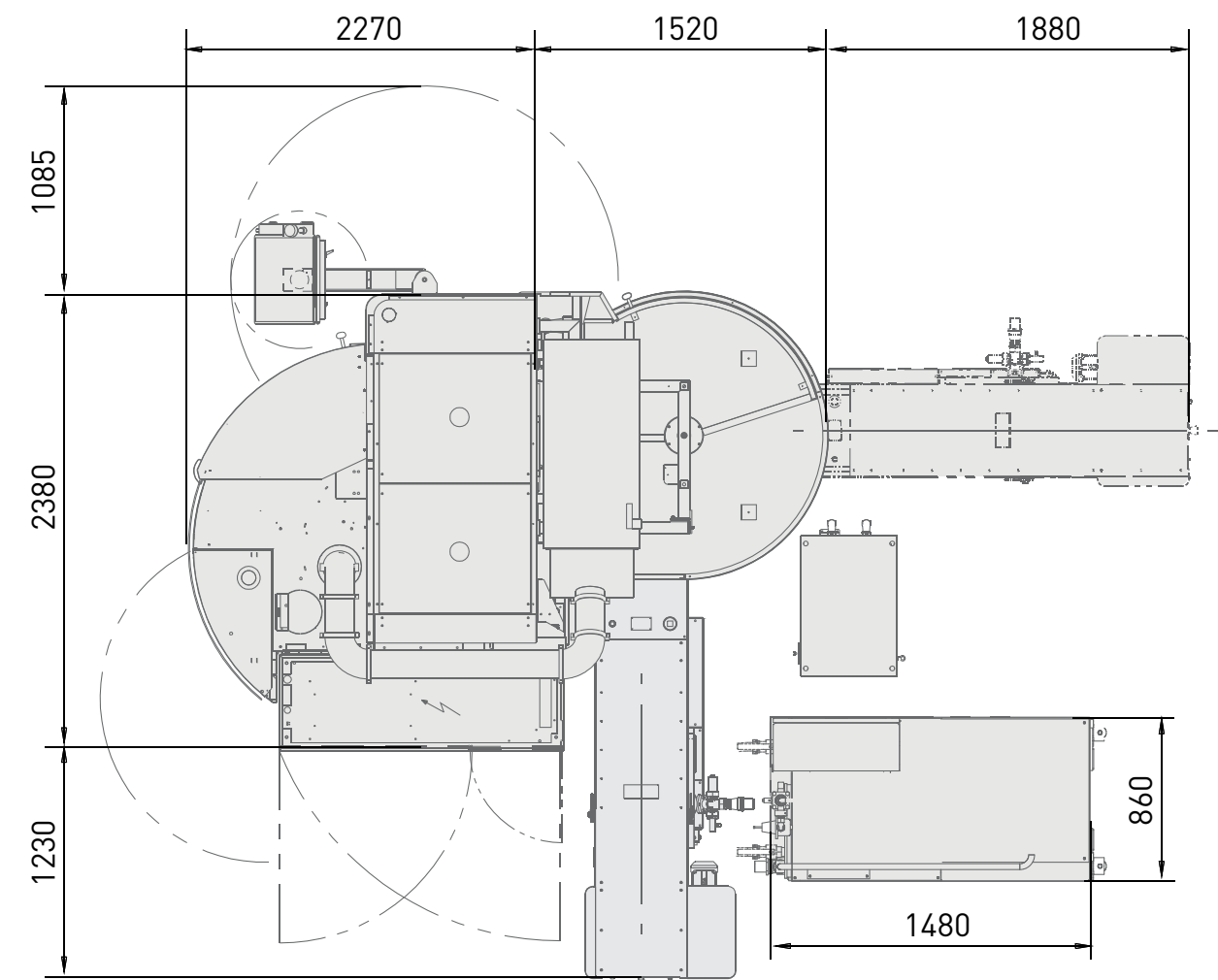
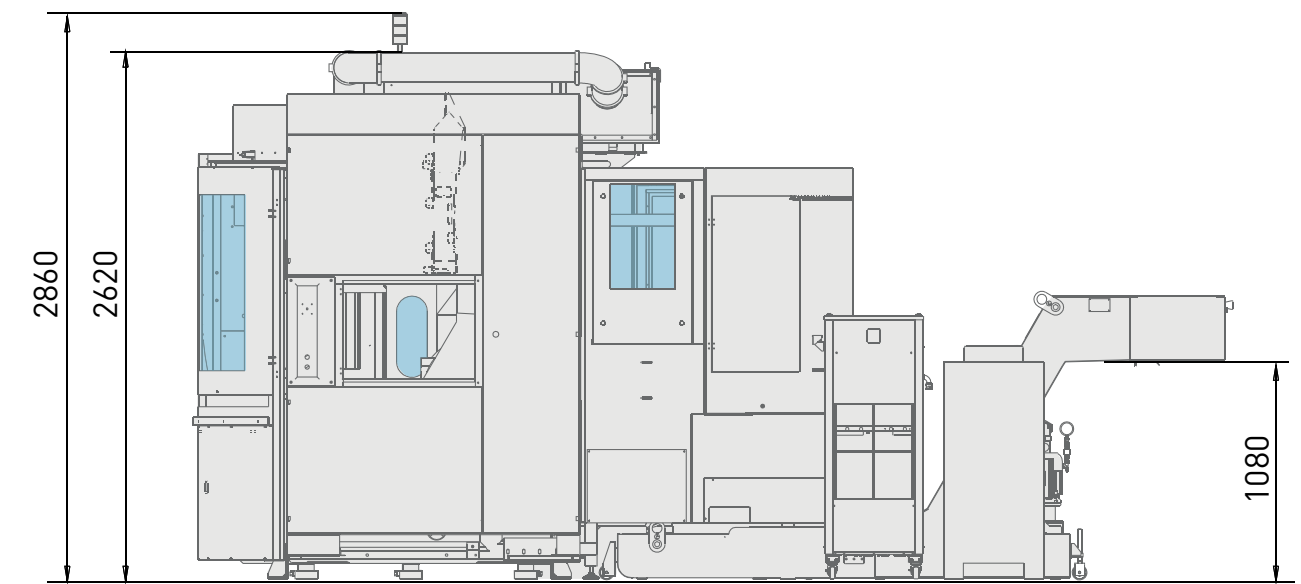

Machine			Mikron MILL S 400	Mikron MILL S 400 U	Mikron MILL S 500
Axis travel					
Lengthwise	X	mm	500	500	500
Crosswise	Y	mm	450	240	450
Vertical	Z	mm	360	360	360
Swiveling axis		°	-	+110/-110	-
Rotary axis		°	-	n x 360	-
Travel speed					
Rapid traverse	X, Y	m/min	61	61	61
Rapid traverse	Z	m/min	61	61	61
Rapid traverse (swivel)		min ⁻¹	-	165	-
Rapid traverse (rotary)		min ⁻¹	-	250	-
Tool Spindle (40% ED, S6)					
60'000 min ⁻¹ , HSK-E32		kW / Nm	8.5 / 3.5	8.5 / 3.5	8.5 / 3.5
42'000 min ⁻¹ , HSK-E40		kW / Nm	13.5 / 8.8	13.5 / 8.8	13.5 / 8.8
30'000 min ⁻¹ , HSK-E40		kW / Nm	13.5 / 8.8	13.5 / 8.8	13.5 / 8.8
Work table					
Pallet/clamping surface	mm		Dynafix 280x280/350x350	MacroMagnum 156	550 x 450
Pallet/clamping surface	mm		GPS 240 x 240	ITS 148	-
Pallet/clamping surface	mm		UPC 320 x 320	-	-
Max. table load	kg		120	25	200
Tool magazine					
HSK-E32	tool holder		20/40	20/40	20/40
HSK-E40	tool holder		18 / 36 / 68 / 168 / 308	18 / 36 / 68 / 168 / 308	18 / 36 / 68 / 168 / 308
Automation					
Pallet size / Number	Piece		UPC/Dynafix / 7x	M.M. 156/18x	-
Pallet size / Number	Piece		GPS 240/10x	ITS 148/20x	-
Maximum additional load	kg		90	25	-
Weight					
Machine	kg		6'800	7'000	6'800
Pallet changer	kg		1'200	1'200	-
Control					
Heidenhain			iTNC 530 HSCI	iTNC 530 HSCI	iTNC 530 HSCI

GF Machining Solutions



EDM (electrical discharge machining)

AgieCharmilles wire-cutting, die-sinking and hole-drilling machines.

For over 60 years we have been at the forefront of every EDM development: designing and refining the EDM process and building machine tools that deliver peerless part accuracies, surface finishes, cutting speeds and process reliability. Today, our AgieCharmilles wire-cutting, die-sinking and hole-drilling machines are recognized throughout the world as the best in the business. Our continuous research and development in digital generator technology, control systems and integrated Automation systems are evidence of our commitment to keeping your EDM operations on the leading edge of technology.



Laser

AgieCharmilles Laser texturing machines.

Laser texturing is a fully-digitized surface engineering process that has huge potential. The technology enables precise 2D and 3D textures or engravings to be machined accurately and directly onto complex parts or molds to improve and alter their aesthetic appeal, functionality and performance. The process is infinitely repeatable and offers many distinct environmental and economic advantages over conventional texturing processes.

Laser Additive Manufacturing (AM).

GF Machining Solutions has partnered with EOS, the global leader for high-end AM solutions, to integrate this innovative technology and further develop it into its current solutions to fully benefit the mold industry, by focusing on injection efficiency: optimized cooling design to reduce cycle time, lower energy consumption, higher quality of plastic parts.



Automation

System 3R Automation, Tooling and software.

Productivity is the key to manufacturing success, and automating a manufacturing process is a proven method of increasing its efficiency, effectiveness, quality and reliability. System 3R's integrated Automation, Tooling and software solutions—simple workpiece pallet and electrode changers and flexible manufacturing and robot handling systems—increase your competitive advantage.



Milling

Mikron high-speed (HSM), high-performance (HPM) and high-efficiency (HEM) Milling centers.

Customers operating in the mold, tool and die and precision component manufacturing sectors stake their reputations on being able to quickly and cost-competitively meet their customers' demands. That's why they invest in Mikron machines. Incorporating the latest and most advanced technologies and premium-performance components, Mikron HSM, HPM and HEM machines help you increase your production capabilities and improve your productivity. Designed and built for speed, accuracy and reliability, the machines, like you, are proven performers.

Liechti Dedicated Aerospace and Energy machining Centers.

Aerospace and power generation turbine manufacturers increasingly turn to Liechti dedicated five- and six-axis machining centers to machine complex, high-precision airfoils on blades, disks, blings, blisks/IBRs and impellers. It's easy to see why because these machines, with their specific profile machining technology, specialized CAD/CAM software and engineering competence for ultra-dynamic machining in titanium, Inconel, nimonic, titanium-aluminide and high-alloy steels, yield productivity gains as much as 30 percent, thanks to reduced machining times. In the globally competitive aerospace and power generation manufacturing sector, that's definitely worth shouting about.

Step-Tec Spindles.

At the heart of every Mikron machining center is high-performance Step-Tec Spindle. Step-Tec Spindles are essential core components of our machining centers. Highly accurate and thermally stable Step-Tec Spindles ensure that our machines can handle everything from heavy-duty roughing to fine-finishing operations.



Customer Services

Operations Support, Machine Support and Business Support.

To help you get the most and the best from your machine tools and equipment, we offer three levels of support. Operations Support covers our range of original wear parts and certified consumables (EDM wires, filters, resins, electrodes etc.) to ensure that your machines are performing at the highest levels. Machine Support maximizes, through our best-in-class technical support, preventive services and quality spare parts, your machine tool uptime. Business Support is designed to help you make a real step-change in your productivity and performance with solutions tailored to your specific needs.

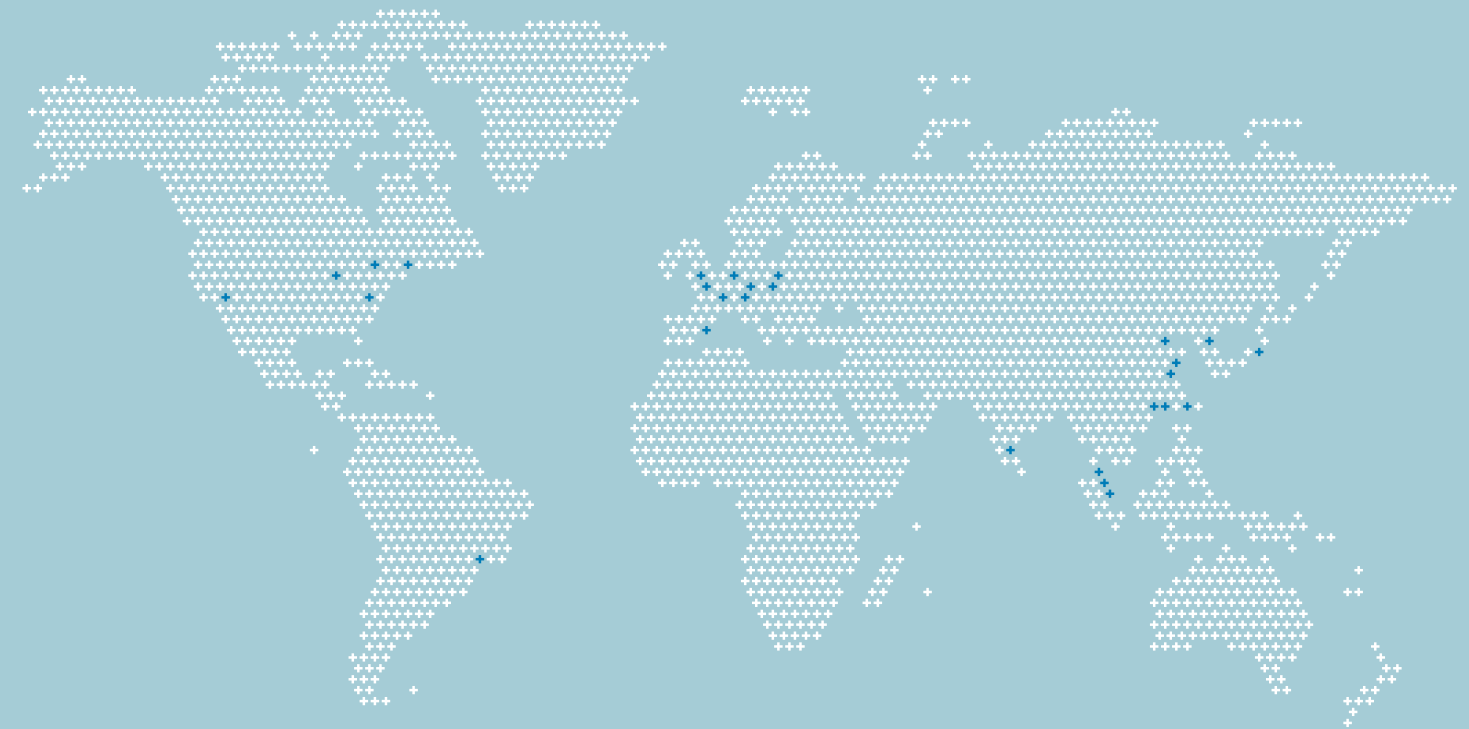

At a glance

We enable our customers to run their businesses efficiently and effectively by offering innovative Milling, EDM, Laser, Spindle, Automation and Tooling solutions. A comprehensive package of Customer Services completes our proposition.

www.gfms.com

