

Press Release

Long version

INDEX G200 turn-mill center

Flexible production machine

The second generation of the successful INDEX G200 turn-mill centers is available: the new G200 comes with extensive improvements, from the machine structure with increased turning length, through an additional tool carrier to the performance of the milling spindle. The result is a machine that is completely geared to the needs of the market: it is flexible for complete machining of both bar stock and chuck parts while being highly productive and fast.



The market demands of modern turn-mill centers high flexibility – but that's not all. The machines must be highly productive and fast while delivering high-quality results, so that production is worthwhile in high-wage countries versus the global competition.

Against this background, lathe manufacturer INDEX has developed a new generation of its successful turn-mill center G200: the new G200 is a compact machine offering significantly higher performance at virtually the same footprint as its predecessor.

A striking change compared to the first generation G200 relates to the machine bed. The heavily ribbed, low-vibration cast construction is now arranged vertically. A concept that INDEX pursues in almost all its new developments due to the process advantages for users. Although the machines tend to be slightly higher by this change, they require little

floor space and provide more space in the work area, which is favorable especially for the lower tool carriers.

The main and counter spindles are designed identically; they are fluid-cooled and feature a bar capacity of 65 mm (chuck up to max. 165 mm diameter). Their motorized spindles allow productive turning machining with a power of 31.5/32 kW (100%/40% duty cycle), a torque of 125/170 Nm and a maximum speed of 6000 rpm.

The redesign of the machine resulted also in a larger work area without affecting the overall dimensions significantly. The maximum turning length is now 660 mm (previously 400 mm).

Additional tool support ensures higher productivity

The enlarged space in the work area was used by the INDEX developers to implement a second lower tool carrier to increase the productivity of the machine. Reducing cycle times by 30% compared to the first G200 generation is well within the bounds of possibility with appropriate workpieces. The two turrets are arranged in mirror image, and each has an independent Y-axis (+/- 45 mm). They contain 14 tool stations (VDI25), which can all be equipped with live tools. The tool drive provides 16 kW and a torque of 16 Nm (each at 25% duty cycle). The maximum speed is 7200 rpm.

Upper tool carrier with turret and integrated milling spindle

A special feature is the upper tool carrier, which has an additional Y-axis (+/- 65 mm) and a 360-degree swiveling B-axis. It is designed on one side as a tool turret with another 14 positions (VDI25) and has – as already proven in the previous G200 – a milling spindle (HSK-A40) on the rear. Its drive comes with a considerable increase in performance on the new G200: while the previous version was limited to a speed of 2000 rpm, the new milling spindle provides speeds up to 7,200 rpm (power 22 kW, torque 52 Nm at 25% duty cycle). The user has a wide choice of tools, from a cutter head for surface milling to small, delicate cutters and drills for workpieces with fine contours.

Flexibility for different machining steps

The G200 has three tool carriers whose tools can be assigned to almost any machining type on the main and counter spindles. This means great flexibility for the programmer in organizing the machining steps.

Due to the large work area, it is even possible to work with three turrets simultaneously on the main spindle or counter spindle, without them interfering with each other. One example: the lower right turret with an angular tool can machine the inside of a workpiece clamped in the main spindle, while the other lower turret and the upper tool carrier machine the outside. The same is also possible on the counter spindle. This increases the possibilities to use three cutting edges simultaneously for maximum productivity.

Flexible tool carriers – parking position for lower tool carriers

The tool carriers have even more features to offer. For example, the upper turret head can be swung into a horizontal position about the B-axis and then moved into the work area up to a position of 30 mm below the spindle center. In this position, the turret can machine towards the main or counter spindle, or even simultaneously depending on the application. This position is often used to perform face and simultaneous machining on the main and counter spindles with straight tools. This is more cost-effective and accurate than with angular tool holders.

Another feature of the lower tool carriers is the so-called parking positions. The turrets are designed to move to the left or right to a position that is outside the work area where there is no risk of collision. This allows the other tool carrier to work absolutely freely over the entire turning length. This comes in handy especially with workpieces such as long shafts, which can be turned completely in this way with one tool without stopping.

Also, with 845 mm, the slide travel of the upper tool carrier is dimensioned in the Z-axis such that the tool covers the complete turning length of 660 mm – without having to rotate the B-axis by 180°, which is often the case on other machine concepts.

Xpanel® i4.0 ready - the cockpit for easy integration of the machine in the operations organization

The Xpanel® i4.0 ready operating concept of the new INDEX G200 generation consistently focuses on productivity and ease of use.

Building on the SIEMENS S840D sl (Solution Line) control, the operating concept developed by INDEX reduces the complexity of handling the control significantly. For example, many control elements of the machine control panel have been integrated in the screen and can be used directly via the 18.5" WideScreen display with the latest capacitive touch technology. A slight touch of the finger is enough to activate functions, to open files and folders, or to move entire display pages. Similarly, direct is also the

integrated operator support: on the machine control panel, active buttons and switches are backlit by LEDs, while inactive ones simply remain dark.

Screen with two faces

But the Xpanel® i4.0 ready operating concept does even more:

In addition to the familiar and comfortable setting up and operating the machine, you can toggle quickly between the control screen and an activity supporting second screen at the push of a button.” The user can quickly toggle between normal control view and a second screen page. Using this feature, Xpanel® i4.0 ready can, for example, display the INDEX Virtual Machine (VM) directly on the machine (option). The operator then switches to the “On-board Virtual Machine” by pressing a button and uses the simulation either independently or coupled with the current machine operation: “CrashStop” allows the advance simulation of workpiece programs on the machine. If the simulation virtually recognizes a collision, the machine is stopped in time before the actual crash; “Real Time” allows real time simulation of the current machine program on the control panel to view the machining sequence, for example, under difficult to see work area situations. Furthermore, the (optional) industrial PC installed in the control cabinet can also be used as “CAM on Board.” This allows the NX CAM system, supported by an INDEX postprocessor, to run directly on the machine, which is particularly useful for extensive milling work.

Open to extensions

Another new feature of the new XPanel® i4.0 ready operating panel is its openness for any information technology (IT) applications. This is because the industrial PC, referred to as the VPC box, in the control panel (option) can also be used for individual customer applications. For example, the machine operator can use the control panel to obtain information from the corporate network, such as component drawings or tool data to set up the machine.

BOX

Advantages of the G200 in detail

- Rigid machine bed in vertical position
- Enlarged work area with up to 660 mm turning length
- Upper tool carrier with additional milling spindle (incl. Y and B-axis)
- Two lower turrets with Y-axis and up to 14 stations
- Excellent ergonomics for quick setup
- Same footprint as predecessor G200

Contact: INDEX-Werke GmbH & Co. KG
Hahn & Tessky
Michael Czudaj
Marketing Director
and Sales Manager Germany and Austria
Phone: +49 711 3191-570
michael.czudaj@index-werke.de



Figure 1

G200: The INDEX turn-mill center combines flexibility and productivity. Despite significantly higher power density, it requires only about the same footprint as the previous model

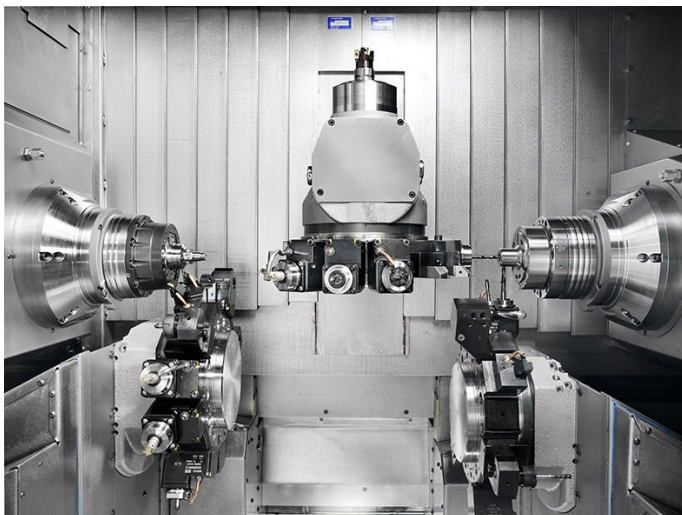

Figure 2

Work area: the vertically arranged machine bed and other smart design features result in a work area that is more spacious than on its predecessor. 660 mm of turning length are now available.

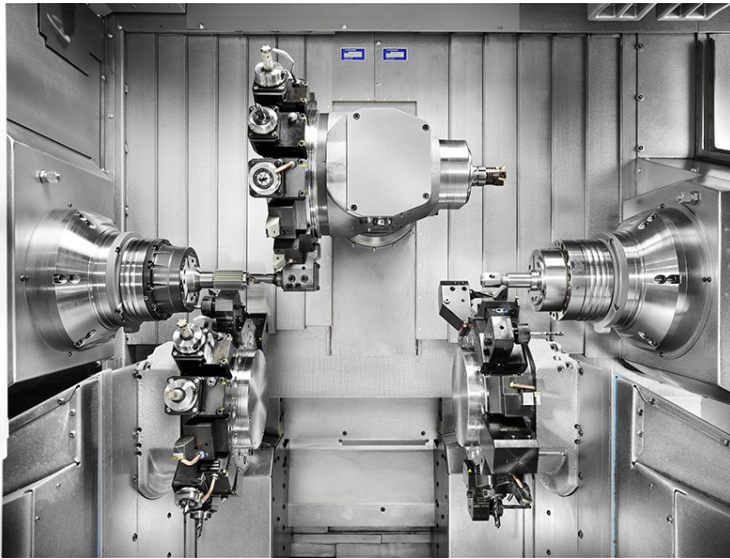

Figure 3

Tool carriers: a second lower turret makes the machine significantly more productive

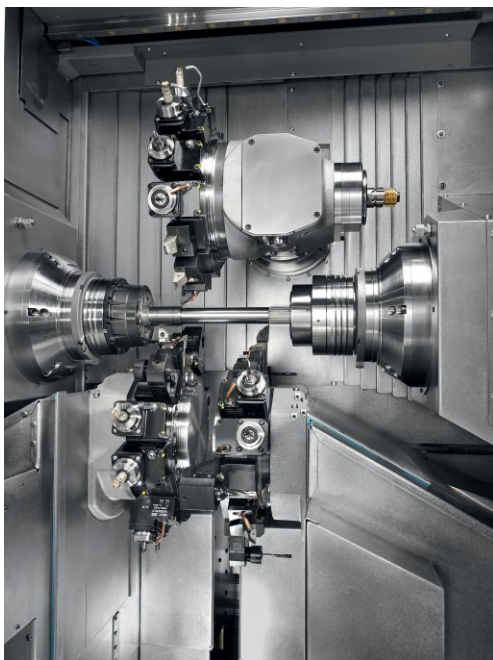

Figure 4

Milling spindle: the upper tool carrier has a milling spindle on its rear that allows through its performance (speed up to 7200 rpm, torque of 52 Nm at 25%) the use of small and large tools.

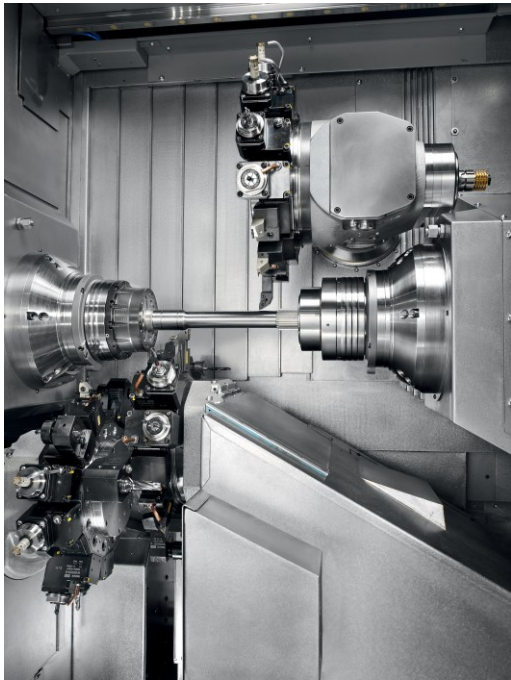

Figure 5

Long shaft parts: due to the generous space, each lower turret can move to a collision-free parking position, while the other machines the complete turning length on its own.



Figure 6

The latest control generation, SIEMENS S840D sl (Solution Line), is part of Xpanel – the cockpit for easy integration of the machine into your business organization. Use Xpanel intuitively via an 18.5" touchscreen monitor.